

**High-Speed CMOS Logic 3- to 8-Line Decoder/  
Demultiplexer Inverting and Non-Inverting**

October 1997 - Revised October 2003

**Features**

- **Select One Of Eight Data Outputs**  
Active Low for 138, Active High for 238
- **I/O Port or Memory Selector**
- **Three Enable Inputs to Simplify Cascading**
- **Typical Propagation Delay of 13ns at  $V_{CC} = 5V$ ,  
 $C_L = 15pF$ ,  $T_A = 25^\circ C$**
- **Fanout (Over Temperature Range)**
  - **Standard Outputs . . . . . 10 LSTTL Loads**
  - **Bus Driver Outputs . . . . . 15 LSTTL Loads**
- **Wide Operating Temperature Range . . .  $-55^\circ C$  to  $125^\circ C$**
- **Balanced Propagation Delay and Transition Times**
- **Significant Power Reduction Compared to LSTTL  
Logic ICs**
- **HC Types**
  - **2V to 6V Operation**
  - **High Noise Immunity:  $N_{IL} = 30\%$ ,  $N_{IH} = 30\%$  of  $V_{CC}$   
at  $V_{CC} = 5V$**
- **HCT Types**
  - **4.5V to 5.5V Operation**
  - **Direct LSTTL Input Logic Compatibility,  
 $V_{IL} = 0.8V$  (Max),  $V_{IH} = 2V$  (Min)**
  - **CMOS Input Compatibility,  $I_I \leq 1\mu A$  at VOL, VOH**

**Description**

The 'HC138, 'HC238, 'HCT138, and 'HCT238 are high speed silicon gate CMOS decoders well suited to memory address decoding or data routing applications. Both circuits feature low power consumption usually associated with CMOS circuitry, yet have speeds comparable to low power Schottky TTL logic. Both circuits have three binary select inputs (A0, A1 and A2). If the device is enabled, these inputs determine which one of the eight normally high outputs of the HC/HCT138 series will go low or which of the normally low outputs of the HC/HCT238 series will go high.

Two active low and one active high enables ( $\overline{E1}$ ,  $\overline{E2}$ , and E3) are provided to ease the cascading of decoders. The decoder's 8 outputs can drive 10 low power Schottky TTL equivalent loads.

**Ordering Information**

PART NUMBER	TEMP. RANGE (°C)	PACKAGE
CD54HC138F3A	-55 to 125	16 Ld CERDIP
CD54HC238F3A	-55 to 125	16 Ld CERDIP
CD54HCT138F3A	-55 to 125	16 Ld CERDIP
CD54HCT238F3A	-55 to 125	16 Ld CERDIP
CD74HC138E	-55 to 125	16 Ld PDIP
CD74HC138M	-55 to 125	16 Ld SOIC
CD74HC138MT	-55 to 125	16 Ld SOIC
CD74HC138M96	-55 to 125	16 Ld SOIC
CD74HC238E	-55 to 125	16 Ld PDIP
CD74HC238M	-55 to 125	16 Ld SOIC
CD74HC238MT	-55 to 125	16 Ld SOIC
CD74HC238M96	-55 to 125	16 Ld SOIC
CD74HC238NSR	-55 to 125	16 Ld SOP
CD74HC238PW	-55 to 125	16 Ld TSSOP
CD74HC238PWR	-55 to 125	16 Ld TSSOP
CD74HC238PWT	-55 to 125	16 Ld TSSOP
CD74HCT138E	-55 to 125	16 Ld PDIP
CD74HCT138M	-55 to 125	16 Ld SOIC
CD74HCT138MT	-55 to 125	16 Ld SOIC
CD74HCT138M96	-55 to 125	16 Ld SOIC
CD74HCT238E	-55 to 125	16 Ld PDIP
CD74HCT238M	-55 to 125	16 Ld SOIC

NOTE: When ordering, use the entire part number. The suffixes 96 and R denote tape and reel. The suffix T denotes a small-quantity reel of 250.

# CD54/74HC138, CD54/74HCT138, CD54/74HC238, CD54/74HCT238

## Pinout

CD54HC138, CD54HCT138, CD54HC238, CD54HCT238  
(CERDIP)  
CD74HC138, CD74HCT138, CD74HCT238  
(PDIP, SOIC)  
CD74HC238  
(PDIP, SOIC, SOP, TSSOP)  
TOP VIEW

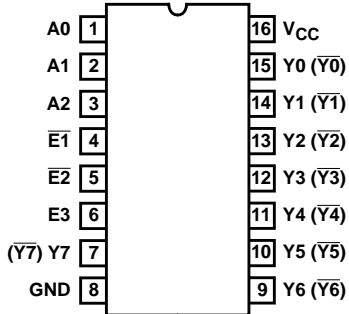

## Functional Diagram

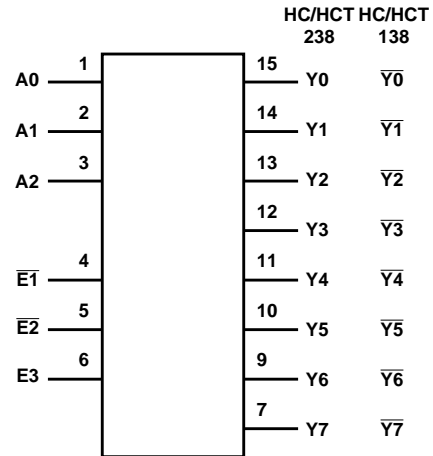

Signal names in parentheses are for 'HC138 and 'HCT138.

TRUTH TABLE 'HC138, 'HCT138

INPUTS						OUTPUTS							
ENABLE			ADDRESS										
E3	E2	E1	A2	A1	A0	Y0	Y1	Y2	Y3	Y4	Y5	Y6	Y7
X	X	H	X	X	X	H	H	H	H	H	H	H	H
L	X	X	X	X	X	H	H	H	H	H	H	H	H
X	H	X	X	X	X	H	H	H	H	H	H	H	H
H	L	L	L	L	L	L	H	H	H	H	H	H	H
H	L	L	L	L	H	H	L	H	H	H	H	H	H
H	L	L	L	H	L	H	H	L	H	H	H	H	H
H	L	L	H	L	L	H	H	H	H	L	H	H	H
H	L	L	H	L	H	H	H	H	H	H	L	H	H
H	L	L	H	H	L	H	H	H	H	H	H	L	H
H	L	L	H	H	H	H	H	H	H	H	H	H	L

H = High Voltage Level, L = Low Voltage Level, X = Don't Care

TRUTH TABLE 'HC238, 'HCT238

INPUTS						OUTPUTS							
ENABLE			ADDRESS										
E3	E2	E1	A2	A1	A0	Y0	Y1	Y2	Y3	Y4	Y5	Y6	Y7
X	X	H	X	X	X	L	L	L	L	L	L	L	L
L	X	X	X	X	X	L	L	L	L	L	L	L	L
X	H	X	X	X	X	L	L	L	L	L	L	L	L
H	L	L	L	L	L	H	L	L	L	L	L	L	L
H	L	L	L	L	H	L	H	L	L	L	L	L	L
H	L	L	L	H	L	L	L	H	L	L	L	L	L
H	L	L	L	H	H	L	L	L	H	L	L	L	L
H	L	L	H	L	L	L	L	L	L	H	L	L	L
H	L	L	H	L	H	L	L	L	L	L	H	L	L
H	L	L	H	H	L	L	L	L	L	L	L	H	L
H	L	L	H	H	H	L	L	L	L	L	L	L	H

H = High Voltage Level, L = Low Voltage Level, X = Don't Care

# CD54/74HC138, CD54/74HCT138, CD54/74HC238, CD54/74HCT238

## Absolute Maximum Ratings

DC Supply Voltage,  $V_{CC}$  ..... -0.5V to 7V  
 DC Input Diode Current,  $I_{IK}$   
 For  $V_I < -0.5V$  or  $V_I > V_{CC} + 0.5V$  .....  $\pm 20mA$   
 DC Output Diode Current,  $I_{OK}$   
 For  $V_O < -0.5V$  or  $V_O > V_{CC} + 0.5V$  .....  $\pm 20mA$   
 DC Output Source or Sink Current per Output Pin,  $I_O$   
 For  $V_O > -0.5V$  or  $V_O < V_{CC} + 0.5V$  .....  $\pm 25mA$   
 DC  $V_{CC}$  or Ground Current,  $I_{CC}$  or  $I_{GND}$  .....  $\pm 50mA$

## Thermal Information

Package Thermal Impedance,  $\theta_{JA}$  (see Note 1):  
 E (PDIP) Package .....  $67^{\circ}C/W$   
 M (SOIC) Package .....  $73^{\circ}C/W$   
 NS (SOP) Package .....  $64^{\circ}C/W$   
 PW (TSSOP) Package .....  $108^{\circ}C/W$   
 Maximum Junction Temperature .....  $150^{\circ}C$   
 Maximum Storage Temperature Range .....  $-65^{\circ}C$  to  $150^{\circ}C$   
 Maximum Lead Temperature (Soldering 10s) .....  $300^{\circ}C$   
 (SOIC - Lead Tips Only)

## Operating Conditions

Temperature Range ( $T_A$ ) .....  $-55^{\circ}C$  to  $125^{\circ}C$   
 Supply Voltage Range,  $V_{CC}$   
 HC Types ..... 2V to 6V  
 HCT Types ..... 4.5V to 5.5V  
 DC Input or Output Voltage,  $V_I, V_O$  ..... 0V to  $V_{CC}$   
 Input Rise and Fall Time  
 2V ..... 1000ns (Max)  
 4.5V ..... 500ns (Max)  
 6V ..... 400ns (Max)

*CAUTION: Stresses above those listed in "Absolute Maximum Ratings" may cause permanent damage to the device. This is a stress only rating and operation of the device at these or any other conditions above those indicated in the operational sections of this specification is not implied.*

### NOTE:

- The package thermal impedance is calculated in accordance with JESD 51-7.

## DC Electrical Specifications

PARAMETER	SYMBOL	TEST CONDITIONS		$V_{CC}$ (V)	25°C			-40°C TO 85°C		-55°C TO 125°C		UNITS
		$V_I$ (V)	$I_O$ (mA)		MIN	TYP	MAX	MIN	MAX	MIN	MAX	
<b>HC TYPES</b>												
High Level Input Voltage	$V_{IH}$	-	-	2	1.5	-	-	1.5	-	1.5	-	V
				4.5	3.15	-	-	3.15	-	3.15	-	V
				6	4.2	-	-	4.2	-	4.2	-	V
Low Level Input Voltage	$V_{IL}$	-	-	2	-	-	0.5	-	0.5	-	0.5	V
				4.5	-	-	1.35	-	1.35	-	1.35	V
				6	-	-	1.8	-	1.8	-	1.8	V
High Level Output Voltage CMOS Loads	$V_{OH}$	$V_{IH}$ or $V_{IL}$	-0.02	2	1.9	-	-	1.9	-	1.9	-	V
			-0.02	4.5	4.4	-	-	4.4	-	4.4	-	V
			-0.02	6	5.9	-	-	5.9	-	5.9	-	V
High Level Output Voltage TTL Loads	$V_{OH}$	$V_{IH}$ or $V_{IL}$	-	-	-	-	-	-	-	-	-	V
			-4	4.5	3.98	-	-	3.84	-	3.7	-	V
			-5.2	6	5.48	-	-	5.34	-	5.2	-	V
Low Level Output Voltage CMOS Loads	$V_{OL}$	$V_{IH}$ or $V_{IL}$	0.02	2	-	-	0.1	-	0.1	-	0.1	V
			0.02	4.5	-	-	0.1	-	0.1	-	0.1	V
			0.02	6	-	-	0.1	-	0.1	-	0.1	V
Low Level Output Voltage TTL Loads	$V_{OL}$	$V_{IH}$ or $V_{IL}$	-	-	-	-	-	-	-	-	-	V
			4	4.5	-	-	0.26	-	0.33	-	0.4	V
			5.2	6	-	-	0.26	-	0.33	-	0.4	V
Input Leakage Current	$I_I$	$V_{CC}$ or GND	-	6	-	-	$\pm 0.1$	-	$\pm 1$	-	$\pm 1$	$\mu A$
Quiescent Device Current	$I_{CC}$	$V_{CC}$ or GND	0	6	-	-	8	-	80	-	160	$\mu A$

**CD54/74HC138, CD54/74HCT138, CD54/74HC238, CD54/74HCT238**

**DC Electrical Specifications (Continued)**

PARAMETER	SYMBOL	TEST CONDITIONS		V <sub>CC</sub> (V)	25°C			-40°C TO 85°C		-55°C TO 125°C		UNITS
		V <sub>I</sub> (V)	I <sub>O</sub> (mA)		MIN	TYP	MAX	MIN	MAX	MIN	MAX	
<b>HCT TYPES</b>												
High Level Input Voltage	V <sub>IH</sub>	-	-	4.5 to 5.5	2	-	-	2	-	2	-	V
Low Level Input Voltage	V <sub>IL</sub>	-	-	4.5 to 5.5	-	-	0.8	-	0.8	-	0.8	V
High Level Output Voltage CMOS Loads	V <sub>OH</sub>	V <sub>IH</sub> or V <sub>IL</sub>	-0.02	4.5	4.4	-	-	4.4	-	4.4	-	V
High Level Output Voltage TTL Loads			-4	4.5	3.98	-	-	3.84	-	3.7	-	V
Low Level Output Voltage CMOS Loads	V <sub>OL</sub>	V <sub>IH</sub> or V <sub>IL</sub>	0.02	4.5	-	-	0.1	-	0.1	-	0.1	V
Low Level Output Voltage TTL Loads			4	4.5	-	-	0.26	-	0.33	-	0.4	V
Input Leakage Current	I <sub>I</sub>	V <sub>CC</sub> and GND	0	5.5	-	-	±0.1	-	±1	-	±1	μA
Quiescent Device Current	I <sub>CC</sub>	V <sub>CC</sub> or GND	0	5.5	-	-	8	-	80	-	160	μA
Additional Quiescent Device Current Per Input Pin: 1 Unit Load	ΔI <sub>CC</sub> (Note 2)	V <sub>CC</sub> -2.1	-	4.5 to 5.5	-	100	360	-	450	-	490	μA

NOTE:

2. For dual-supply systems theoretical worst case (V<sub>I</sub> = 2.4V, V<sub>CC</sub> = 5.5V) specification is 1.8mA.

**HCT Input Loading Table**

INPUT	UNIT LOADS
A0-A2	1.5
E1, E2	1.25
E3	1

NOTE: Unit Load is ΔI<sub>CC</sub> limit specified in DC Electrical Table, e.g., 360μA max at 25°C.

**Switching Specifications** Input t<sub>r</sub>, t<sub>f</sub> = 6ns

PARAMETER	SYMBOL	TEST CONDITIONS	V <sub>CC</sub> (V)	25°C			-40°C TO 85°C		-55°C TO 125°C		UNITS
				MIN	TYP	MAX	MIN	MAX	MIN	MAX	
<b>HC TYPES</b>											
Propagation Delay Address to Output	t <sub>PLH</sub> , t <sub>PHL</sub>	C <sub>L</sub> = 50pF	2	-	-	150	-	190	-	225	ns
			4.5	-	-	30	-	38	-	45	ns
		C <sub>L</sub> = 15pF	5	-	13	-	-	-	-	-	ns
			C <sub>L</sub> = 50pF	6	-	-	26	-	33	-	38

**CD54/74HC138, CD54/74HCT138, CD54/74HC238, CD54/74HCT238**

**Switching Specifications** Input  $t_r, t_f = 6\text{ns}$  (Continued)

PARAMETER	SYMBOL	TEST CONDITIONS	$V_{CC}$ (V)	25°C			-40°C TO 85°C		-55°C TO 125°C		UNITS
				MIN	TYP	MAX	MIN	MAX	MIN	MAX	
Enable to Output HC/HCT138	$t_{PLH}, t_{PHL}$	$C_L = 50\text{pF}$	2	-	-	150	-	190	-	265	ns
			4.5	-	-	30	-	38	-	53	ns
			6	-	-	26	-	33	-	45	ns
Output Transition Time (Figure 1)	$t_{TLH}, t_{THL}$	$C_L = 50\text{pF}$	2	-	-	75	-	95	-	110	ns
			4.5	-	-	15	-	19	-	22	ns
			6	-	-	13	-	16	-	19	ns
Power Dissipation Capacitance, (Notes 3, 4)	$C_{PD}$	$C_L = 15\text{pF}$	5	-	67	-	-	-	-	-	pF
Input Capacitance	$C_{IN}$	-	-	-	-	10	-	10	-	10	pF
<b>HCT TYPES</b>											
Propagation Delay Address to Output	$t_{PLH}, t_{PHL}$	$C_L = 50\text{pF}$	4.5	-	-	35	-	44	-	53	ns
		$C_L = 15\text{pF}$	5	-	14	-	-	-	-	-	ns
Enable to Output HC/HCT138	$t_{PLH}, t_{PHL}$	$C_L = 50\text{pF}$	4.5	-	-	35	-	44	-	53	ns
Enable to Output HC/HCT238	$t_{PLH}, t_{PHL}$	$C_L = 15\text{pF}$	4.5	-	-	40	-	50	-	60	ns
Output Transition Time (Figure 2)	$t_{TLH}, t_{THL}$	$C_L = 50\text{pF}$	4.5	-	-	15	-	19	-	22	ns
Power Dissipation Capacitance, (Notes 3, 4)	$C_{PD}$	$C_L = 15\text{pF}$	5	-	67	-	-	-	-	-	pF
Input Capacitance	$C_{IN}$	-	-	-	-	10	-	10	-	10	pF

NOTES:

- $C_{PD}$  is used to determine the dynamic power consumption, per gate.
- $P_D = V_{CC}^2 f_i (C_{PD} + C_L)$  where:  $f_i$  = Input Frequency,  $C_L$  = Output Load Capacitance,  $V_{CC}$  = Supply Voltage.

**Test Circuits and Waveforms**

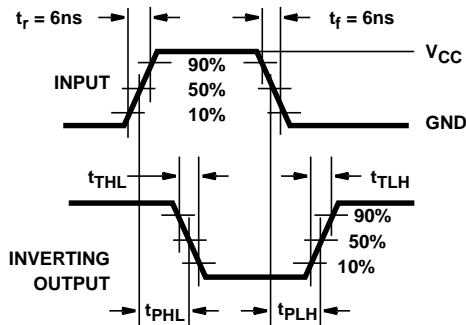

FIGURE 7. HC AND HCU TRANSITION TIMES AND PROPAGATION DELAY TIMES, COMBINATION LOGIC

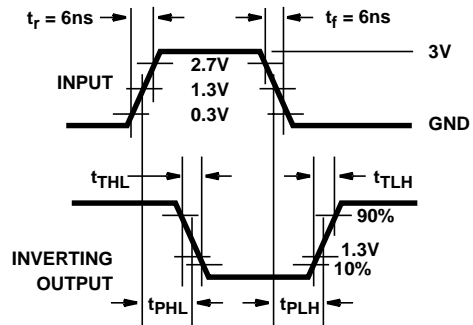

FIGURE 8. HCT TRANSITION TIMES AND PROPAGATION DELAY TIMES, COMBINATION LOGIC