

# SN5450, SN7450

## DUAL 2-WIDE 2-INPUT AND-OR-INVERT GATES (ONE GATE EXPANDABLE)

SDLS112 – DECEMBER 1983 – REVISED MARCH 1988

- Package Options Include Plastic and Ceramic DIPs and Ceramic Flat Packages
- Dependable Texas Instruments Quality and Reliability

### description

These devices contain two independent 2-wide 2-input AND-OR-INVERT gates with one gate expandable. They perform the Boolean function  $Y = \overline{AB + CD}$  with X and  $\overline{X}$  left open.

The SN5450 is characterized for operation over the full military temperature range of  $-55^{\circ}\text{C}$  to  $125^{\circ}\text{C}$ . The SN7450 is characterized for operation from  $0^{\circ}\text{C}$  to  $70^{\circ}\text{C}$ .

### logic symbol†

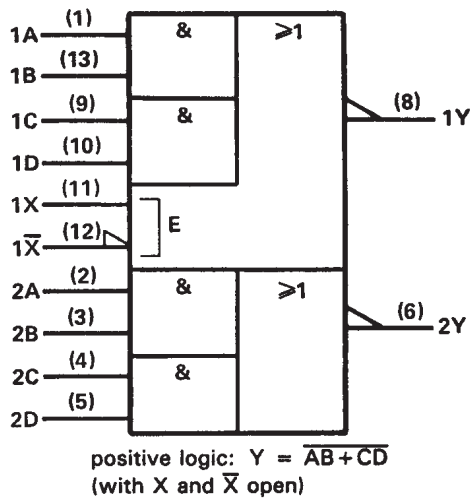

† This symbol is in accordance with ANSI/IEEE Std 91-1984 and IEC Publication 617-12.

Pin numbers shown are for J and N packages.

SN5450 . . . J PACKAGE  
SN7450 . . . N PACKAGE  
(TOP VIEW)

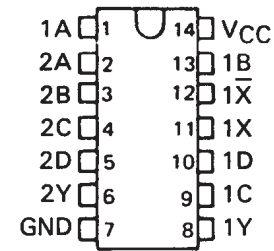

SN5450 . . . W PACKAGE  
(TOP VIEW)

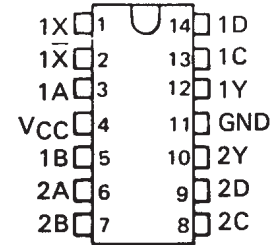

### logic diagram (positive logic)

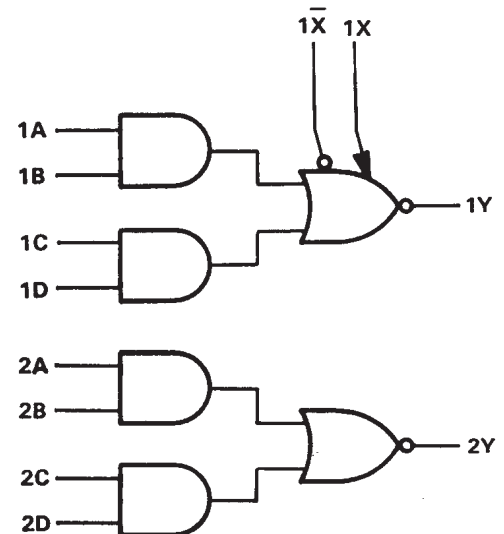



# SN5450, SN7450

## DUAL 2-WIDE 2-INPUT AND-OR-INVERT GATES (ONE GATE EXPANDABLE)

SDLS112 – DECEMBER 1983 – REVISED MARCH 1988

### recommended operating conditions

	SN5450			SN7450			UNIT
	MIN	NOM	MAX	MIN	NOM	MAX	
V <sub>CC</sub> Supply voltage	4.5	5	5.5	4.75	5	5.25	V
V <sub>IH</sub> High-level input voltage	2			2			V
V <sub>IL</sub> Low-level input voltage			0.8			0.8	V
I <sub>OH</sub> High-level output current			-0.4			-0.4	mA
I <sub>OL</sub> Low-level output current			16			16	mA
T <sub>A</sub> Operating free-air temperature	-55		125	0		70	°C

### electrical characteristics over recommended operating free-air temperature range (unless otherwise noted)

PARAMETER	TEST CONDITIONS†	SN5450			SN7450			UNIT
		MIN	TYP‡	MAX	MIN	TYP‡	MAX	
V <sub>IK</sub>	V <sub>CC</sub> = MIN, I <sub>I</sub> = -12 mA			-1.5			-1.5	V
V <sub>OH</sub>	V <sub>CC</sub> = MIN, V <sub>IL</sub> = 0.8 V, I <sub>OH</sub> = -0.4 mA	2.4	3.4		2.4	3.4		V
V <sub>OL</sub>	V <sub>CC</sub> = MIN, V <sub>IH</sub> = 2 V, I <sub>OL</sub> = 16 mA		0.2	0.4		0.2	0.4	V
I <sub>I</sub>	V <sub>CC</sub> = MAX, V <sub>I</sub> = 5.5 V			1			1	mA
I <sub>IH</sub>	V <sub>CC</sub> = MAX, V <sub>IH</sub> = 2.4 V			40			40	μA
I <sub>IL</sub>	V <sub>CC</sub> = MAX, V <sub>IL</sub> = 0.4 V			-1.6			-1.6	mA
I <sub>OS</sub> §	V <sub>CC</sub> = MAX	-20		-55	-18		-55	mA
I <sub>CCH</sub>	V <sub>CC</sub> = MAX, V <sub>I</sub> = 0 V		4	8		4	8	mA
I <sub>CCL</sub>	V <sub>CC</sub> = MAX, See Note 2		7.4	14		7.4	14	mA
I <sub>X</sub> ¶	V <sub>X</sub> = 0.4 V, I <sub>OL</sub> = 16 mA			-2.9			-3.1	mA
V <sub>BE(Q)</sub> ¶	I <sub>X</sub> + I <sub>X</sub> = 0.41 mA, R <sub>X</sub> = 0, I <sub>OL</sub> = 16 mA			1.1				V
	I <sub>X</sub> + I <sub>X</sub> = 0.62 mA, R <sub>X</sub> = 0, I <sub>OL</sub> = 16 mA						1	
V <sub>OH</sub> ¶	I <sub>X</sub> = 0.15 mA, I <sub>X</sub> = -0.15 mA, I <sub>OH</sub> = -0.4 mA	2.4	3.4					V
	I <sub>X</sub> = 0.27 mA, I <sub>X</sub> = -0.27 mA, I <sub>OH</sub> = -0.4 mA				2.4	3.4		
V <sub>OL</sub> ¶	I <sub>X</sub> + I <sub>X</sub> = 0.3 mA, R <sub>X</sub> = 138 Ω, I <sub>OL</sub> = 16 mA		0.2	0.4				V
	I <sub>X</sub> + I <sub>X</sub> = 0.43 mA, R <sub>X</sub> = 130 Ω, I <sub>OL</sub> = 16 mA					0.2	0.4	

† For conditions shown as MIN or MAX, use the appropriate value specified under recommended operating conditions.

‡ All typical values are at V<sub>CC</sub> = 5 V, T<sub>A</sub> = 25° C.

§ Not more than one output should be shorted at a time.

¶ Using expander inputs, V<sub>CC</sub> = MIN, T<sub>A</sub> = MIN, except typical values.

NOTE 2: All inputs of one AND gate at 4.5 V, all others at GND.

### switching characteristics, V<sub>CC</sub> = 5 V, T<sub>A</sub> = 25° C (see note 3)

PARAMETER	FROM (INPUT)	TO (OUTPUT)	TEST CONDITIONS	MIN	TYP	MAX	UNIT
t <sub>PLH</sub>	Any	Y	R <sub>L</sub> = 400 Ω, C <sub>L</sub> = 15 pF Expander pins open		13	22	ns
t <sub>PHL</sub>					8	15	ns

NOTE 3: Load circuits and voltage waveforms are shown in Section 1.

