

# SN5445, SN7445 BCD-TO-DECIMAL DECODERS/DRIVERS

SDLS110

DECEMBER 1972 - REVISED MARCH 1988

FOR USE AS LAMP, RELAY, OR MOS DRIVERS

featuring

- Full Decoding of Input Logic
- 80-mA Sink-Current Capability
- All Outputs Are Off for Invalid BCD Input Conditions

SN5445 . . . J OR W PACKAGE

SN7445 . . . N PACKAGE

(TOP VIEW)

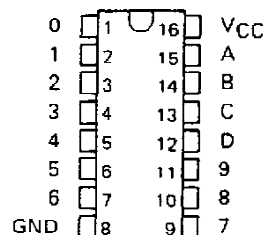

FUNCTION TABLE

NO.	INPUTS				OUTPUTS									
	D	C	B	A	0	1	2	3	4	5	6	7	8	9
0	L	L	L	L	L	H	H	H	H	H	H	H	H	H
1	L	L	L	H	H	L	H	H	H	H	H	H	H	H
2	L	L	H	L	H	H	L	H	H	H	H	H	H	H
3	L	L	H	H	H	H	H	L	H	H	H	H	H	H
4	L	H	L	L	H	H	H	H	L	H	H	H	H	H
5	L	H	L	H	H	H	H	H	H	L	H	H	H	H
6	L	H	H	L	H	H	H	H	H	H	L	H	H	H
7	L	H	H	H	H	H	H	H	H	H	H	L	H	H
8	H	L	L	L	H	H	H	H	H	H	H	H	L	H
9	H	L	L	H	H	H	H	H	H	H	H	H	H	L
INVALID	H	L	H	L	H	H	H	H	H	H	H	H	H	H
	H	L	H	H	H	H	H	H	H	H	H	H	H	H
	H	H	L	L	H	H	H	H	H	H	H	H	H	H
	H	H	L	H	H	H	H	H	H	H	H	H	H	H
	H	H	H	L	H	H	H	H	H	H	H	H	H	H

H = high level (off), L = low level (on)

## description

These monolithic BCD-to-decimal decoders/drivers consist of eight inverters and ten four-input NAND gates. The inverters are connected in pairs to make BCD input data available for decoding by the NAND gates. Full decoding of valid BCD input logic ensures that all outputs remain off for all invalid binary input conditions. These decoders feature TTL inputs and high-performance, n-p-n output transistors designed for use as indicator/relay drivers or as open-collector logic-circuit drivers. Each of the high-breakdown output transistors (30 volts) will sink up to 80 milliamperes of current. Each input is one normalized Series 54/74 load. Inputs and outputs are entirely compatible for use with TTL logic circuits, and the outputs are compatible for interfacing with most MOS integrated circuits. Power dissipation is typically 215 milliwatts.

## logic diagram (positive logic)

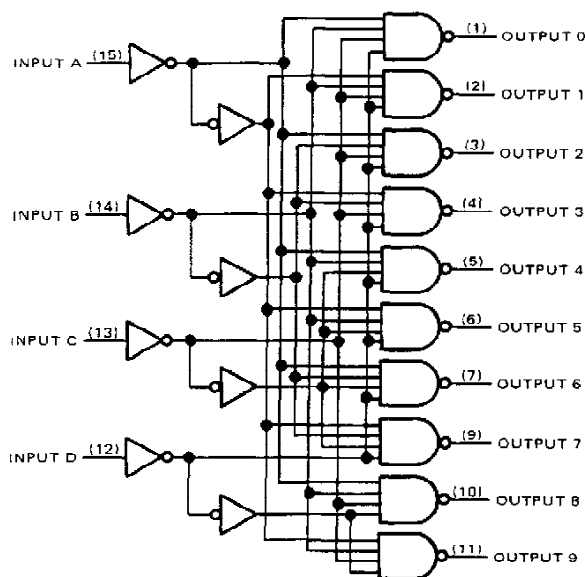

## logic symbol

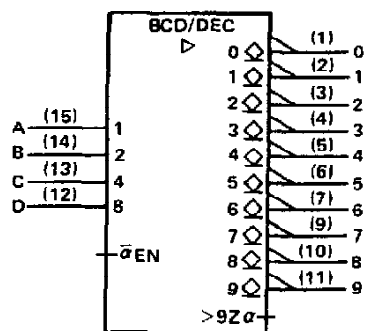

Pin numbers shown are for J, N, and W packages.

PRODUCTION DATA documents contain information current as of publication date. Products conform to specifications per the terms of Texas Instruments standard warranty. Production processing does not necessarily include testing of all parameters.

TEXAS  
INSTRUMENTS

POST OFFICE BOX 655012 • DALLAS, TEXAS 75265

# SN5445, SN7445 BCD-TO-DECIMAL DECODERS/DRIVERS

absolute maximum ratings over operating free-air temperature range (unless otherwise noted)

Supply voltage, $V_{CC}$ (see Note 1)	7 V
Input voltage	5.5 V
Maximum current into any output (off-state)	1 mA
Operating free-air temperature range: SN5445 Circuits	-55°C to 125°C
SN7445 Circuits	0°C to 70°C
Storage temperature range	-65°C to 150°C

NOTE 1: Voltage values are with respect to network ground terminal.

## recommended operating conditions

	SN5445			SN7445			UNIT
	MIN	NOM	MAX	MIN	NOM	MAX	
Supply voltage, $V_{CC}$	4.5	5	5.5	4.75	5	5.25	V
Off-state output voltage			30			30	V
Operating free-air temperature, $T_A$	-55		125	0		70	°C

## electrical characteristics over recommended operating free-air temperature range (unless otherwise noted)

PARAMETER	TEST CONDITIONS†	MIN	TYP‡	MAX	UNIT	
$V_{IH}$ High-level input voltage		2			V	
$V_{IL}$ Low-level input voltage				0.8	V	
$V_{IK}$ Input clamp voltage	$V_{CC} = \text{MIN}, I_I = -12 \text{ mA}$			-1.5	V	
$V_{O(\text{on})}$ On-state output voltage	$V_{CC} = \text{MIN}, V_{IH} = 2 \text{ V}, V_{IL} = 0.8 \text{ V}$			0.5	0.9	V
					0.4	V
$I_{O(\text{off})}$ Off-state output current	$V_{CC} = \text{MIN}, V_{IH} = 2 \text{ V}, V_{IL} = 0.8 \text{ V}, V_{O(\text{off})} = 30 \text{ V}$			250	μA	
$I_I$ Input current at maximum input voltage	$V_{CC} = \text{MAX}, V_I \approx 5.5 \text{ V}$			1	mA	
$I_{IH}$ High-level input current	$V_{CC} = \text{MAX}, V_I = 2.4 \text{ V}$			40	μA	
$I_{IL}$ Low-level input current	$V_{CC} = \text{MAX}, V_I = 0.4 \text{ V}$			-1.6	mA	
$I_{CC}$ Supply current	$V_{CC} = \text{MAX}, \text{ See Note 2}$			43	62	mA
				43	70	mA

† For conditions shown as MIN or MAX, use the appropriate value specified under recommended operating conditions for the applicable type.

‡ All typical values are at  $V_{CC} = 5 \text{ V}, T_A = 25^\circ \text{C}$ .

NOTE 2:  $I_{CC}$  is measured with all inputs grounded and outputs open.

## switching characteristics, $V_{CC} = 5 \text{ V}, T_A = 25^\circ \text{C}$

PARAMETER	TEST CONDITIONS	MIN	TYP	MAX	UNIT
$t_{PLH}$ Propagation delay time, low-to-high-level output	$C_L = 15 \text{ pF}, R_L = 100 \Omega, \text{ See Note 3}$			50	ns
$t_{PHL}$ Propagation delay time, high-to-low-level output				50	ns

NOTE 3: Load circuits and voltage waveforms are shown in Section 1.

## schematics of inputs and outputs

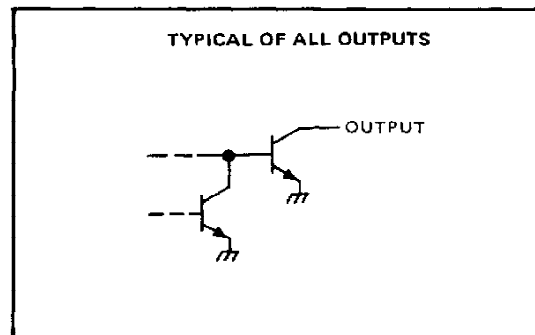
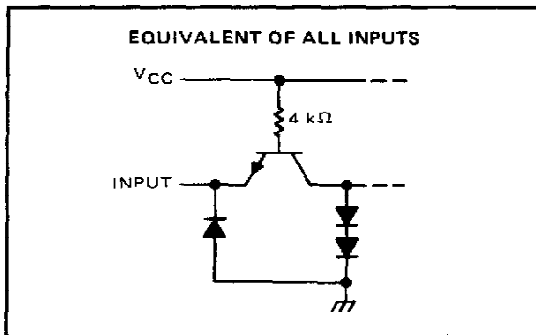

TEXAS  
INSTRUMENTS

POST OFFICE BOX 655012 • DALLAS, TEXAS 75265