

SN54LS253, SN54S253, SN74LS253, SN74S253 DUAL 4-LINE TO 1-LINE DATA SELECTORS/MULTIPLEXERS WITH 3-STATE OUTPUTS

SDLS147 – SEPTEMBER 1972 – REVISED MARCH 1988

- Three-State Version of SN54/74LS153, SN54/74S153
- Schottky-Diode-Clamped Transistors
- Permits Multiplexing from N Lines to 1 Line
- Performs Parallel-to-Serial Conversion
- Fully Compatible with Most TTL Circuits
- Low Power Dissipation
 'LS253 . . . 35 mW Typical
 'S253 . . . 225 mW Typical

SN54LS253, SN54S253 . . . J OR W PACKAGE
 SN74LS253, SN74S253 . . . D OR N PACKAGE

(TOP VIEW)

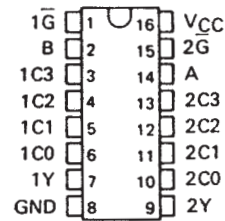

SN54LS253, SN54S253 . . . FK PACKAGE

(TOP VIEW)

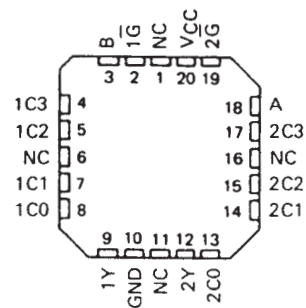

NC-No internal connection

description

Each of these Schottky-clamped data selectors/multiplexers contains inverters and drivers to supply fully complementary, on-chip, binary decoding data selection to the AND-OR gates. Separate output control inputs are provided for each of the two four-line sections.

The three-state outputs can interface with and drive data lines of bus-organized systems. With all but one of the common outputs disabled (at a high-impedance state) the low-impedance of the single enabled output will drive the bus line to a high or low logic level.

FUNCTION TABLE

SELECT INPUTS		DATA INPUTS				OUTPUT CONTROL	OUTPUT
B	A	C0	C1	C2	C3	G	Y
X	X	X	X	X	X	H	Z
L	L	L	X	X	X	L	L
L	L	H	X	X	X	L	H
L	H	X	L	X	X	L	L
L	H	X	H	X	X	L	H
H	L	X	X	L	X	L	L
H	L	X	X	H	X	L	H
H	H	X	X	X	L	L	L
H	H	X	X	X	H	L	H

Address inputs A and B are common to both sections.
 H = high level, L = low level, X = irrelevant, Z = high impedance (off)

absolute maximum ratings over operating free-air temperature range (unless otherwise noted)

Supply voltage, V_{CC} (see Note 1)	7 V
Input voltage: 'LS253	7 V
'S253	5.5 V
Off-state output voltage	5.5 V
Operating free-air temperature range: SN54LS253, SN54S253	-55°C to 125°C
SN74LS253, SN74S253	0°C to 70°C
Storage temperature range	-65°C to 150°C

NOTE 1: Voltage values are with respect to network ground terminal.

PRODUCTION DATA information is current as of publication date. Products conform to specifications per the terms of Texas Instruments standard warranty. Production processing does not necessarily include testing of all parameters.



POST OFFICE BOX 655303 • DALLAS, TEXAS 75265

Copyright © 1988, Texas Instruments Incorporated

SN54LS253, SN54S253, SN74LS253, SN74S253 DUAL 4-LINE TO 1-LINE DATA SELECTORS/MULTIPLEXERS WITH 3-STATE OUTPUTS

SDLS147 – SEPTEMBER 1972 – REVISED MARCH 1988

logic symbol†

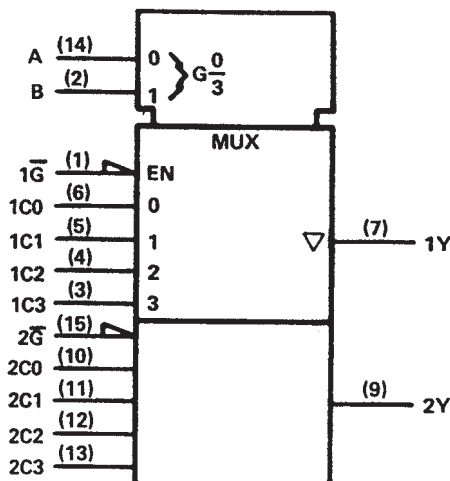

† This symbol is in accordance with ANSI/IEEE Std 91-1984 and IEC Publication 617-12.

logic diagram (positive logic)

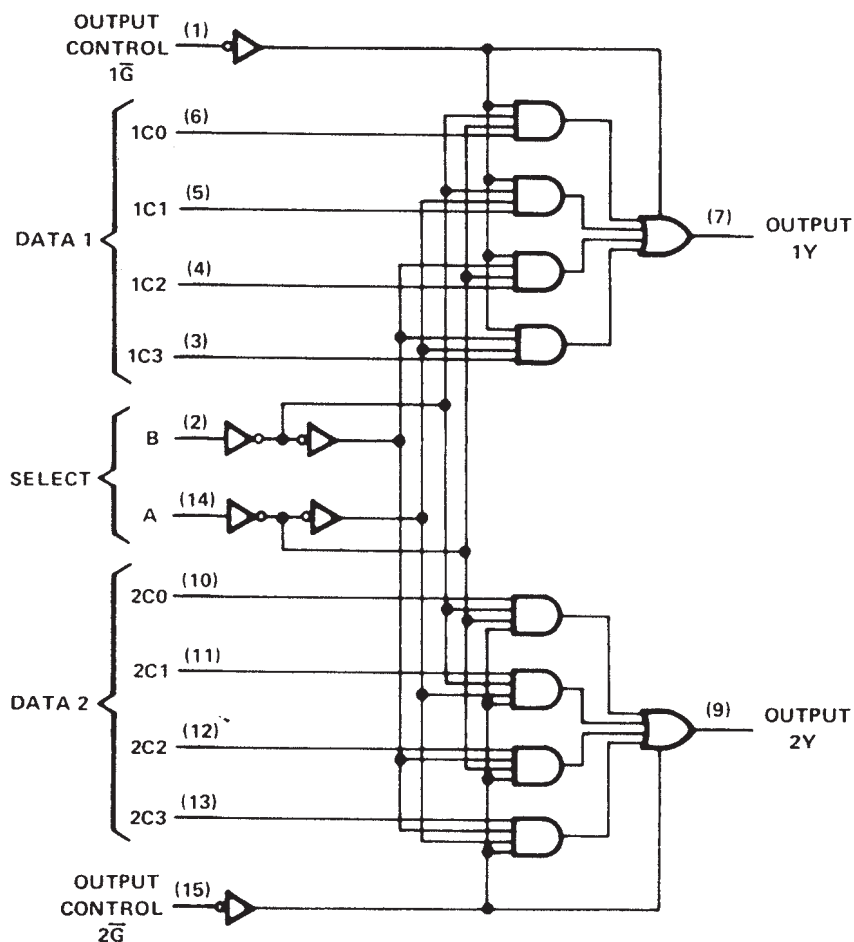

Pin numbers shown are for D, J, N, and W packages.



POST OFFICE BOX 655303 • DALLAS, TEXAS 75265

SN54LS253, SN54S253, SN74LS253, SN74S253 DUAL 4-LINE TO 1-LINE DATA SELECTORS/MULTIPLEXERS WITH 3-STATE OUTPUTS

SDLS147 - SEPTEMBER 1972 - REVISED MARCH 1988

schematic (each selector/multiplexer, and the common select section)

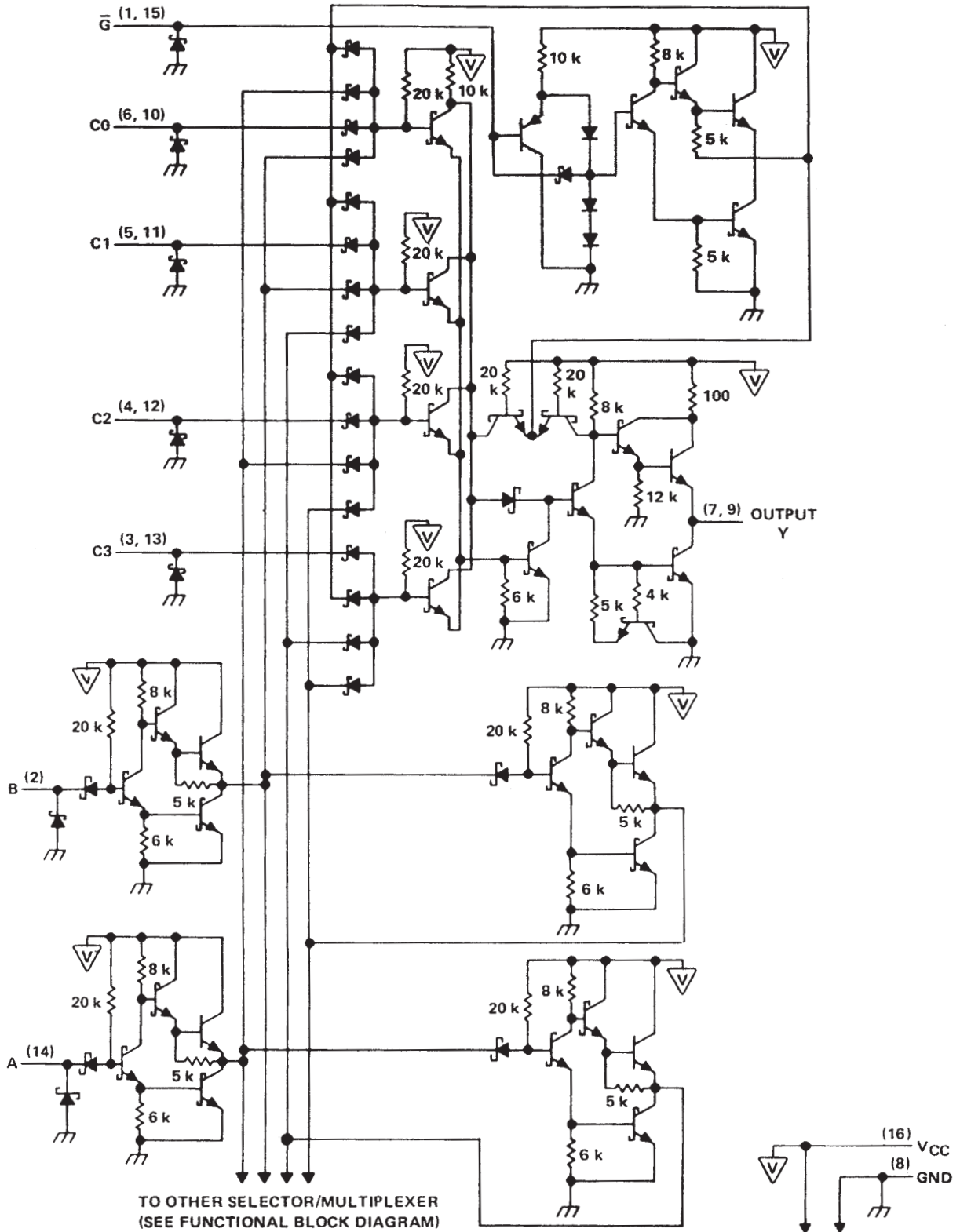

Pin numbers shown are for D, J, N, and W packages.



SN54LS253, SN54S253, SN74LS253, SN74S253 DUAL 4-LINE TO 1-LINE DATA SELECTORS/MULTIPLEXERS WITH 3-STATE OUTPUTS

SDLS147 – SEPTEMBER 1972 – REVISED MARCH 1988

recommended operating conditions

	SN54LS253			SN74LS253			UNIT
	MIN	NOM	MAX	MIN	NOM	MAX	
V _{CC} Supply voltage	4.5	5	5.5	4.75	5	5.25	V
V _{IH} High-level input voltage	2			2			V
V _{IL} Low-level input voltage	0.7			0.8			V
I _{OH} High-level output current	-1			-2.6			mA
I _{OL} Low-level output current	4			8			mA
T _A Operating free-air temperature	-55			0			°C

electrical characteristics over recommended operating free-air temperature range (unless otherwise noted)

PARAMETER	TEST CONDITIONS†	SN54LS253		SN74LS253		UNIT
		MIN	TYP‡	MAX	MIN	
V _{IK}	V _{CC} = MIN, I _I = -18 mA	-1.5		-1.5		V
V _{OH}	V _{CC} = MIN, V _{IH} = 2 V, V _{IL} = MAX, I _{OH} = MAX	2.4	3.4	2.4	3.1	V
V _{OL}	V _{CC} = MIN, V _{IH} = 2 V, V _{IL} = MAX	I _{OL} = 4 mA		0.25		0.4
		I _{OL} = 8 mA		0.25		0.5
I _{OZ}	V _{CC} = MAX, V _{IH} = 2 V	V _O = 2.7 V		20		μA
		V _O = 0.4 V		-20		
I _I	V _{CC} = MAX, V _I = 7 V	0.1		0.1		mA
I _{IH}	V _{CC} = MAX, V _I = 2.7 V	20		20		μA
I _{IL}	V _{CC} = MAX, V _I = 0.4 V	G̅		-0.2		mA
		All other		-0.4		
I _{OS} §	V _{CC} = MAX	-30	-130	-30	-130	mA
I _{CC}	V _{CC} = MAX, See Note 2	Condition A		7		12
		Condition B		8.5		14

† For conditions shown as MIN or MAX, use the appropriate value specified under recommended operating conditions.

‡ All typical values are at V_{CC} = 5 V, T_A = 25°C.

§ Not more than one output should be shorted at a time, and duration for the short-circuit should exceed one second.

NOTE 2: I_{CC} is measured with the outputs open under the following conditions:

- A. All inputs grounded.
- B. Output control at 4.5 V, all inputs grounded.

switching characteristics, V_{CC} = 5 V, T_A = 25°C

PARAMETER	FROM (INPUT)	TO (OUTPUT)	TEST CONDITIONS	MIN	TYP	MAX	UNIT
t _{PLH}	Data	Y	C _L = 15 pF, R _L = 2 kΩ, See Note 3	17		25	ns
t _{PHL}				13		20	
t _{PLH}	Select	Y		30		45	ns
t _{PHL}				21		32	
t _{PZH}	Output	Y		15		28	ns
t _{PZL}	Control			15		23	
t _{PHZ}	Output	Y	C _L = 5 pF, R _L = 2 kΩ, See Note 3	27		41	ns
t _{PLZ}				Control	18		

NOTE 3: Load circuits and voltage waveforms are shown in Section 1.



SN54LS253, SN54S253, SN74LS253, SN74S253 DUAL 4-LINE TO 1-LINE DATA SELECTORS/MULTIPLEXERS WITH 3-STATE OUTPUTS

SDLS147 – SEPTEMBER 1972 – REVISED MARCH 1988

recommended operating conditions

	SN54S253			SN74S253			UNIT
	MIN	NOM	MAX	MIN	NOM	MAX	
V _{CC} Supply voltage	4.5	5	5.5	4.75	5	5.25	V
V _{IH} High-level input voltage	2			2			V
V _{IL} Low-level input voltage	0.8			0.8			V
I _{OH} High-level output current	-2			-6.5			mA
I _{OL} Low-level output current	20			20			mA
T _A Operating free-air temperature	-55			125			°C

electrical characteristics over recommended operating free-air temperature range (unless otherwise noted)

PARAMETER	TEST CONDITIONS†	MIN	TYP‡	MAX	UNIT
V _{IK}	V _{CC} = MIN, I _I = -18 mA	-1.2			V
V _{OH}	V _{CC} = MIN, V _{IH} = 2 V, V _{IL} = 0.8 V, I _{OH} = MAX	Series 54S	2.5	3.4	V
		Series 74S	2.7	3.4	
V _{OL}	V _{CC} = MIN, V _{IH} = 2 V, V _{IL} = 0.8 V, I _{OL} = 20 mA	0.5			V
I _{OZ}	V _{CC} = MAX, V _{IH} = 2 V	V _O = 2.4 V	50		μA
		V _O = 0.5 V	-50		
I _I	V _{CC} = MAX, V _I = 5.5 V	1			mA
I _{IH}	V _{CC} = MAX, V _I = 2.7 V	50			μA
I _{IL}	V _{CC} = MAX, V _I = 0.5 V	\bar{G} = 0.8 V	-2		mA
		\bar{G} = 2 V	-0.25		
I _{OS§}	V _{CC} = MAX	-40	-100		mA
I _{CC}	V _{CC} = MAX, See Note 2	Condition A	45	70	mA
		Condition B	65	85	

† For conditions shown as MIN or MAX, use the appropriate value specified under recommended operating conditions.

‡ All typical values are at V_{CC} = 5 V, T_A = 25°C.

Not more than one output should be shorted at a time and duration of short-circuit should not exceed one second.

NOTE 2: I_{CC} is measured with the outputs open under the following conditions:

- A. All inputs grounded.
- B. Output control at 4.5 V, all inputs grounded.

switching characteristics, V_{CC} = 5 V, T_A = 25°C

PARAMETER	FROM (INPUT)	TO (OUTPUT)	TEST CONDITIONS	MIN	TYP	MAX	UNIT
t _{PLH}	Data	Y	R _L = 280 Ω, See Note 3	C _L = 15 pF	6	9	ns
t _{PHL}					6	9	
t _{PLH}	Select	Y			11.5	18	ns
t _{PHL}					12	18	
t _{PZH}	Output	Y			11	16.5	ns
t _{PZL}	Control				12	18	
t _{PHZ}	Output	Y	R _L = 280 Ω, See Note 3	C _L = 5 pF	6.5	9.5	ns
t _{PLZ}	Control				10	15	

NOTE 3: Load circuits and voltage waveforms are shown in Section 1.

