

Features

- Synchronous Counting and Asynchronous Loading
- Two Outputs for N-Bit Cascading
- Look-Ahead Carry for High-Speed Counting
- Fanout (Over Temperature Range)
 - Standard Outputs 10 LSTTL Loads
 - Bus Driver Outputs 15 LSTTL Loads
- Wide Operating Temperature Range . . . -55°C to 125°C
- Balanced Propagation Delay and Transition Times
- Significant Power Reduction Compared to LSTTL Logic ICs
- HC Types
 - 2V to 6V Operation
 - High Noise Immunity: $N_{IL} = 30\%$, $N_{IH} = 30\%$ of V_{CC} at $V_{CC} = 5V$
- HCT Types
 - 4.5V to 5.5V Operation
 - Direct LSTTL Input Logic Compatibility, $V_{IL} = 0.8V$ (Max), $V_{IH} = 2V$ (Min)
 - CMOS Input Compatibility, $I_I \leq 1\mu A$ at V_{OL} , V_{OH}

Description

The 'HC192, 'HC193 and 'HCT193 are asynchronously presettable BCD Decade and Binary Up/Down synchronous counters, respectively.

Pinout

CD54HC192, CD54HC193, CD54HCT193 (CERDIP)
 CD74HC192 (PDIP, SOP, TSSOP)
 CD74HC193 (PDIP, SOIC)
 CD74HCT193 (PDIP)
 TOP VIEW

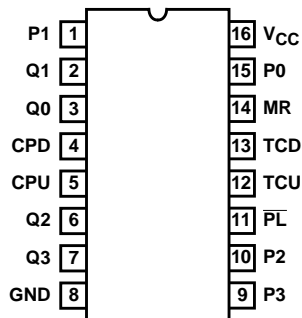

Presetting the counter to the number on the preset data inputs (P0-P3) is accomplished by a LOW asynchronous parallel load input (\overline{PL}). The counter is incremented on the low-to-high transition of the Clock-Up input (and a high level on the Clock-Down input) and decremented on the low to high transition of the Clock-Down input (and a high level on the Clock-up input). A high level on the MR input overrides any other input to clear the counter to its zero state. The Terminal Count up (carry) goes low half a clock period before the zero count is reached and returns to a high level at the zero count. The Terminal Count Down (borrow) in the count down mode likewise goes low half a clock period before the maximum count (9 in the 192 and 15 in the 193) and returns to high at the maximum count. Cascading is effected by connecting the carry and borrow outputs of a less significant counter to the Clock-Up and Clock-Down inputs, respectively, of the next most significant counter.

If a decade counter is preset to an illegal state or assumes an illegal state when power is applied, it will return to the normal sequence in one count as shown in state diagram.

Ordering Information

PART NUMBER	TEMP. RANGE (°C)	PACKAGE
CD54HC192F3A	-55 to 125	16 Ld CERDIP
CD54HC193F3A	-55 to 125	16 Ld CERDIP
CD54HCT193F3A	-55 to 125	16 Ld CERDIP
CD74HC192E	-55 to 125	16 Ld PDIP
CD74HC192NSR	-55 to 125	16 Ld SOP
CD74HC192PW	-55 to 125	16 Ld TSSOP
CD74HC192PWR	-55 to 125	16 Ld TSSOP
CD74HC192PWT	-55 to 125	16 Ld TSSOP
CD74HC193E	-55 to 125	16 Ld PDIP
CD74HC193M	-55 to 125	16 Ld SOIC
CD74HC193MT	-55 to 125	16 Ld SOIC
CD74HC193M96	-55 to 125	16 Ld SOIC
CD74HCT193E	-55 to 125	16 Ld PDIP

NOTE: When ordering, use the entire part number. The suffixes 96 and R denote tape and reel. The suffix T denotes a small-quantity reel of 250.

Functional Diagram



TRUTH TABLE

CLOCK UP	CLOCK DOWN	RESET	PARALLEL LOAD	FUNCTION
↑	H	L	H	Count Up
H	↑	L	H	Count Down
X	X	H	X	Reset
X	X	L	L	Load Preset Inputs

H = High Voltage Level, L = Low Voltage Level, X = Don't Care, ↑ = Transition from Low to High Level

CD54/74HC192, CD54/74HC193, CD54/74HCT193

Absolute Maximum Ratings

DC Supply Voltage, V_{CC}	-0.5V to 7V
DC Input Diode Current, I_{IK}	
For $V_I < -0.5V$ or $V_I > V_{CC} + 0.5V$	$\pm 20mA$
DC Output Diode Current, I_{OK}	
For $V_O < -0.5V$ or $V_O > V_{CC} + 0.5V$	$\pm 20mA$
DC Output Source or Sink Current per Output Pin, I_O	
For $V_O > -0.5V$ or $V_O < V_{CC} + 0.5V$	$\pm 25mA$
DC V_{CC} or Ground Current, I_{CC} or I_{GND}	$\pm 50mA$

Thermal Information

Package Thermal Impedance, θ_{JA} (see Note 1):	
E (PDIP) Package	67°C/W
M (SOIC) Package	73°C/W
NS (SOP) Package	64°C/W
PW (TSSOP) Package	108°C/W
Maximum Junction Temperature	150°C
Maximum Storage Temperature Range	-65°C to 150°C
Maximum Lead Temperature (Soldering 10s)	300°C
(SOIC - Lead Tips Only)	

Operating Conditions

Temperature Range (T_A)	-55°C to 125°C
Supply Voltage Range, V_{CC}	
HC Types2V to 6V
HCT Types	4.5V to 5.5V
DC Input or Output Voltage, V_I , V_O	0V to V_{CC}
Input Rise and Fall Time	
2V	1000ns (Max)
4.5V	500ns (Max)
6V	400ns (Max)

CAUTION: Stresses above those listed in "Absolute Maximum Ratings" may cause permanent damage to the device. This is a stress only rating and operation of the device at these or any other conditions above those indicated in the operational sections of this specification is not implied.

NOTE:

- The package thermal impedance is calculated in accordance with JESD 51-7.

DC Electrical Specifications

PARAMETER	SYMBOL	TEST CONDITIONS			25°C			-40°C TO 85°C		-55°C TO 125°C		UNITS
		V_I (V)	I_O (mA)	V_{CC} (V)	MIN	TYP	MAX	MIN	MAX	MIN	MAX	
HC TYPES												
High Level Input Voltage	V_{IH}	-	-	2	1.5	-	-	1.5	-	1.5	-	V
				4.5	3.15	-	-	3.15	-	3.15	-	V
				6	4.2	-	-	4.2	-	4.2	-	V
Low Level Input Voltage	V_{IL}	-	-	2	-	-	0.5	-	0.5	-	0.5	V
				4.5	-	-	1.35	-	1.35	-	1.35	V
				6	-	-	1.8	-	1.8	-	1.8	V
High Level Output Voltage CMOS Loads	V_{OH}	V_{IH} or V_{IL}	-0.02	2	1.9	-	-	1.9	-	1.9	-	V
			-0.02	4.5	4.4	-	-	4.4	-	4.4	-	V
High Level Output Voltage TTL Loads	V_{OH}	V_{IH} or V_{IL}	-0.02	6	5.9	-	-	5.9	-	5.9	-	V
			-4	4.5	3.98	-	-	3.84	-	3.7	-	V
Low Level Output Voltage CMOS Loads	V_{OL}	V_{IH} or V_{IL}	0.02	2	-	-	0.1	-	0.1	-	0.1	V
			0.02	4.5	-	-	0.1	-	0.1	-	0.1	V
Low Level Output Voltage TTL Loads	V_{OL}	V_{IH} or V_{IL}	0.02	6	-	-	0.1	-	0.1	-	0.1	V
			4	4.5	-	-	0.26	-	0.33	-	0.4	V
Input Leakage Current	I_I	V_{CC} or GND	0	6	-	-	0.26	-	0.33	-	0.4	V
			5.2	6	-	-	0.26	-	0.33	-	0.4	V
Input Leakage Current	I_I	V_{CC} or GND	-	6	-	-	± 0.1	-	± 1	-	± 1	μA
Quiescent Device Current	I_{CC}	V_{CC} or GND	0	6	-	-	8	-	80	-	160	μA

CD54/74HC192, CD54/74HC193, CD54/74HCT193

DC Electrical Specifications (Continued)

PARAMETER	SYMBOL	TEST CONDITIONS			25°C			-40°C TO 85°C		-55°C TO 125°C		UNITS
		V _I (V)	I _O (mA)	V _{CC} (V)	MIN	TYP	MAX	MIN	MAX	MIN	MAX	
HCT TYPES												
High Level Input Voltage	V _{IH}	-	-	4.5 to 5.5	2	-	-	2	-	2	-	V
Low Level Input Voltage	V _{IL}	-	-	4.5 to 5.5	-	-	0.8	-	0.8	-	0.8	V
High Level Output Voltage CMOS Loads	V _{OH}	V _{IH} or V _{IL}	-0.02	4.5	4.4	-	-	4.4	-	4.4	-	V
High Level Output Voltage TTL Loads			-4	4.5	3.98	-	-	3.84	-	3.7	-	V
Low Level Output Voltage CMOS Loads	V _{OL}	V _{IH} or V _{IL}	0.02	4.5	-	-	0.1	-	0.1	-	0.1	V
Low Level Output Voltage TTL Loads			4	4.5	-	-	0.26	-	0.33	-	0.4	V
Input Leakage Current	I _I	V _{CC} to GND	-	5.5	-	-	±0.1	-	±1	-	±1	μA
Quiescent Device Current	I _{CC}	V _{CC} or GND	-	5.5	-	-	8	-	80	-	160	μA
Additional Quiescent Device Current Per Input Pin: 1 Unit Load	ΔI _{CC} (Note 2)	V _{CC} - 2.1	-	4.5 to 5.5	-	100	360	-	450	-	490	μA

NOTE:

- For dual-supply systems theoretical worst case (V_I = 2.4V, V_{CC} = 5.5V) specification is 1.8mA.

HCT Input Loading Table

INPUT	UNIT LOADS
P0-P3	0.4
MR	1.45
PL	0.85
CPU, CPD	1.45

NOTE: Unit Load is ΔI_{CC} limit specified in DC Electrical Specifications table, e.g. 360μA max at 25°C.

CD54/74HC192, CD54/74HC193, CD54/74HCT193

Prerequisite For Switching Specifications

PARAMETER	SYMBOL	V _{CC} (V)	25°C			-40°C TO 85°C		-55°C TO 125°C		UNITS
			MIN	TYP	MAX	MIN	MAX	MIN	MAX	
HC TYPES										
Pulse Width CPU, CPD 192	t _W	2	115	-	-	145	-	175	-	ns
		4.5	23	-	-	29	-	35	-	ns
		6	20	-	-	25	-	30	-	ns
CPU, CPD 193	t _W	2	100	-	-	125	-	150	-	ns
		4.5	20	-	-	25	-	30	-	ns
		6	17	-	-	21	-	26	-	ns
\overline{PL}	t _W	2	80	-	-	100	-	120	-	ns
		4.5	16	-	-	20	-	24	-	ns
		6	14	-	-	17	-	20	-	ns
MR	t _W	2	100	-	-	125	-	150	-	ns
		4.5	20	-	-	25	-	30	-	ns
		6	17	-	-	21	-	26	-	ns
Set-up Time Pn to \overline{PL}	t _{SU}	2	80	-	-	100	-	120	-	ns
		4.5	16	-	-	20	-	24	-	ns
		6	14	-	-	17	-	20	-	ns
Hold Time Pn to \overline{PL}	t _H	2	0	-	-	0	-	0	-	ns
		4.5	0	-	-	0	-	0	-	ns
		6	0	-	-	0	-	0	-	ns
Hold Time CPD to CPU or CPU to CPD	t _H	2	80	-	-	100	-	120	-	ns
		4.5	16	-	-	20	-	24	-	ns
		6	14	-	-	17	-	20	-	ns
Recovery Time \overline{PL} to CPU, CPD	t _{REC}	2	80	-	-	100	-	120	-	ns
		4.5	16	-	-	20	-	24	-	ns
		6	14	-	-	17	-	20	-	ns
MR to CPU, CPD	t _{REC}	2	5	-	-	5	-	5	-	ns
		4.5	5	-	-	5	-	5	-	ns
		6	5	-	-	5	-	5	-	ns
Maximum Frequency CPU, CPD 192	f _{MAX}	2	5	-	-	4	-	3	-	MHz
		4.5	22	-	-	18	-	15	-	MHz
		6	24	-	-	21	-	18	-	MHz
CPU, CPD 193	f _{MAX}	2	5	-	-	4	-	3	-	MHz
		4.5	25	-	-	20	-	17	-	MHz
		6	29	-	-	24	-	20	-	MHz
HCT TYPES										
Pulse Width CPU, CPD 192	t _W	2	-	-	-	-	-	-	-	ns
		4.5	23	-	-	29	-	35	-	ns
		6	-	-	-	-	-	-	-	ns
CPU, CPD 193	t _W	2	-	-	-	-	-	-	-	ns
		4.5	23	-	-	29	-	35	-	ns
		6	-	-	-	-	-	-	-	ns

CD54/74HC192, CD54/74HC193, CD54/74HCT193

Prerequisite For Switching Specifications (Continued)

PARAMETER	SYMBOL	V _{CC} (V)	25°C			-40°C TO 85°C		-55°C TO 125°C		UNITS
			MIN	TYP	MAX	MIN	MAX	MIN	MAX	
\overline{PL}	t _W	2	-	-	-	-	-	-	-	ns
		4.5	16	-	-	20	-	24	-	ns
		6	-	-	-	-	-	-	-	ns
MR	t _W	2	-	-	-	-	-	-	-	ns
		4.5	20	-	-	25	-	30	-	ns
		6	-	-	-	-	-	-	-	ns
Set-up Time P _n to \overline{PL}	t _{SU}	2	-	-	-	-	-	-	-	ns
		4.5	15	-	-	19	-	22	-	ns
		6	-	-	-	-	-	-	-	ns
Hold Time P _n to \overline{PL}	t _H	2	-	-	-	-	-	-	-	ns
		4.5	0	-	-	0	-	0	-	ns
		6	-	-	-	-	-	-	-	ns
Hold Time CPD to CPU or CPU to CPD	t _H	2	-	-	-	-	-	-	-	ns
		4.5	16	-	-	20	-	24	-	ns
		6	-	-	-	-	-	-	-	ns
Recovery Time \overline{PL} to CPU, CPD	t _{REC}	2	-	-	-	-	-	-	-	ns
		4.5	15	-	-	19	-	22	-	ns
		6	-	-	-	-	-	-	-	ns
MR to CPU, CPD	t _{REC}	2	-	-	-	-	-	-	-	ns
		4.5	5	-	-	5	-	5	-	ns
		6	-	-	-	-	-	-	-	ns
Maximum Frequency CPU, CPD 192	f _{MAX}	2	-	-	-	-	-	-	-	MHz
		4.5	22	-	-	18	-	15	-	MHz
		6	-	-	-	-	-	-	-	MHz
CPU, CPD 193	f _{MAX}	2	-	-	-	-	-	-	-	MHz
		4.5	22	-	-	18	-	15	-	MHz
		6	-	-	-	-	-	-	-	MHz

Switching Specifications Input t_r, t_f = 6ns

PARAMETER	SYMBOL	TEST CONDITIONS	V _{CC} (V)	25°C			-40°C TO 85°C		-55°C TO 125°C		UNITS
				MIN	TYP	MAX	MIN	MAX	MIN	MAX	
HC TYPES											
Propagation Delay CPU to \overline{TCU}	t _{PLH} , t _{PHL}	C _L = 50pF	2	-	-	125	-	155	-	190	ns
		C _L = 50pF	4.5	-	-	25	-	31	-	38	ns
		C _L = 15pF	5	-	10	-	-	-	-	-	ns
		C _L = 50pF	6	-	-	21	-	26	-	32	ns
CPD to \overline{TCU}	t _{PLH} , t _{PHL}	C _L = 50pF	2	-	-	125	-	155	-	190	ns
		C _L = 50pF	4.5	-	-	25	-	31	-	38	ns
		C _L = 15pF	5	-	10	-	-	-	-	-	ns
		C _L = 50pF	6	-	-	21	-	26	-	32	ns
CPU to Q _n	t _{PLH} , t _{PHL}	C _L = 50pF	2	-	-	220	-	270	-	325	ns
		C _L = 50pF	4.5	-	-	43	-	54	-	65	ns
		C _L = 15pF	5	-	18	-	-	-	-	-	ns
		C _L = 50pF	6	-	-	37	-	46	-	55	ns

CD54/74HC192, CD54/74HC193, CD54/74HCT193

Switching Specifications Input $t_r, t_f = 6\text{ns}$ (Continued)

PARAMETER	SYMBOL	TEST CONDITIONS	V _{CC} (V)	25°C			-40°C TO 85°C		-55°C TO 125°C		UNITS
				MIN	TYP	MAX	MIN	MAX	MIN	MAX	
CPD to Q _n	t _{PLH} , t _{PHL}	C _L = 50pF	2	-	-	220	-	270	-	325	ns
		C _L = 50pF	4.5	-	-	43	-	54	-	65	ns
		C _L = 15pF	5	-	18	-	-	-	-	-	ns
		C _L = 50pF	6	-	-	37	-	46	-	55	ns
P _L to Q _n	t _{PLH} , t _{PHL}	C _L = 50pF	2	-	-	220	-	275	-	330	ns
		C _L = 50pF	4.5	-	-	44	-	55	-	66	ns
		C _L = 15pF	5	-	18	-	-	-	-	-	ns
		C _L = 50pF	6	-	-	37	-	47	-	56	ns
MR to Q _n	t _{PHL}	C _L = 50pF	2	-	-	200	-	250	-	300	ns
		C _L = 50pF	4.5	-	-	40	-	50	-	60	ns
		C _L = 15pF	5	-	17	-	-	-	-	-	ns
		C _L = 50pF	6	-	-	34	-	43	-	51	ns
Transition Time Q, TCU, TCD	t _{TLH} , t _{THL}	C _L = 50pF	2	-	-	75	-	95	-	110	ns
			4.5	-	-	15	-	19	-	22	ns
			6	-	-	13	-	16	-	19	ns
Input Capacitance	C _{IN}	C _L = 50pF	-	-	-	10	-	10	-	10	pF
Power Dissipation Capacitance (Notes 3, 4)	C _{PD}	C _L = 15pF	5	-	40	-	-	-	-	-	pF
HCT TYPES											
Propagation Delay CPU to TCU	t _{PLH} , t _{PHL}	C _L = 50pF	4.5	-	-	27	-	34	-	41	ns
		C _L = 15pF	5	-	11	-	-	-	-	-	ns
CPU to TCD	t _{PLH} , t _{PHL}	C _L = 50pF	4.5	-	-	27	-	34	-	41	ns
		C _L = 15pF	5	-	11	-	-	-	-	-	ns
CPU to Q _n	t _{PLH} , t _{PHL}	C _L = 50pF	4.5	-	-	40	-	50	-	60	ns
		C _L = 15pF	5	-	17	-	-	-	-	-	ns
CPD to Q _n	t _{PLH} , t _{PHL}	C _L = 50pF	4.5	-	-	40	-	50	-	60	ns
		C _L = 15pF	5	-	17	-	-	-	-	-	ns
P _L to Q _n	t _{PLH} , t _{PHL}	C _L = 50pF	4.5	-	-	46	-	58	-	69	ns
		C _L = 15pF	5	-	21	-	-	-	-	-	ns
MR to Q _n	t _{PHL}	C _L = 50pF	4.5	-	-	43	-	54	-	65	ns
		C _L = 15pF	5	-	18	-	-	-	-	-	ns
Transition Time Q, TCU, TCD	t _{TLH} , t _{THL}	C _L = 50pF	2	-	-	75	-	95	-	110	ns
			4.5	-	-	15	-	19	-	22	ns
Input Capacitance	C _{IN}	C _L = 50pF	-	-	-	10	-	10	-	10	pF
Power Dissipation Capacitance (Notes 3, 4)	C _{PD}	C _L = 15pF	5	-	50	-	-	-	-	-	pF

NOTES:

- C_{PD} is used to determine the dynamic power consumption, per gate.
- $P_D = V_{CC}^2 f_i + \sum (C_L V_{CC}^2)$ where f_i = Input Frequency, C_L = Output Load Capacitance, V_{CC} = Supply Voltage.

Test Circuits and Waveforms

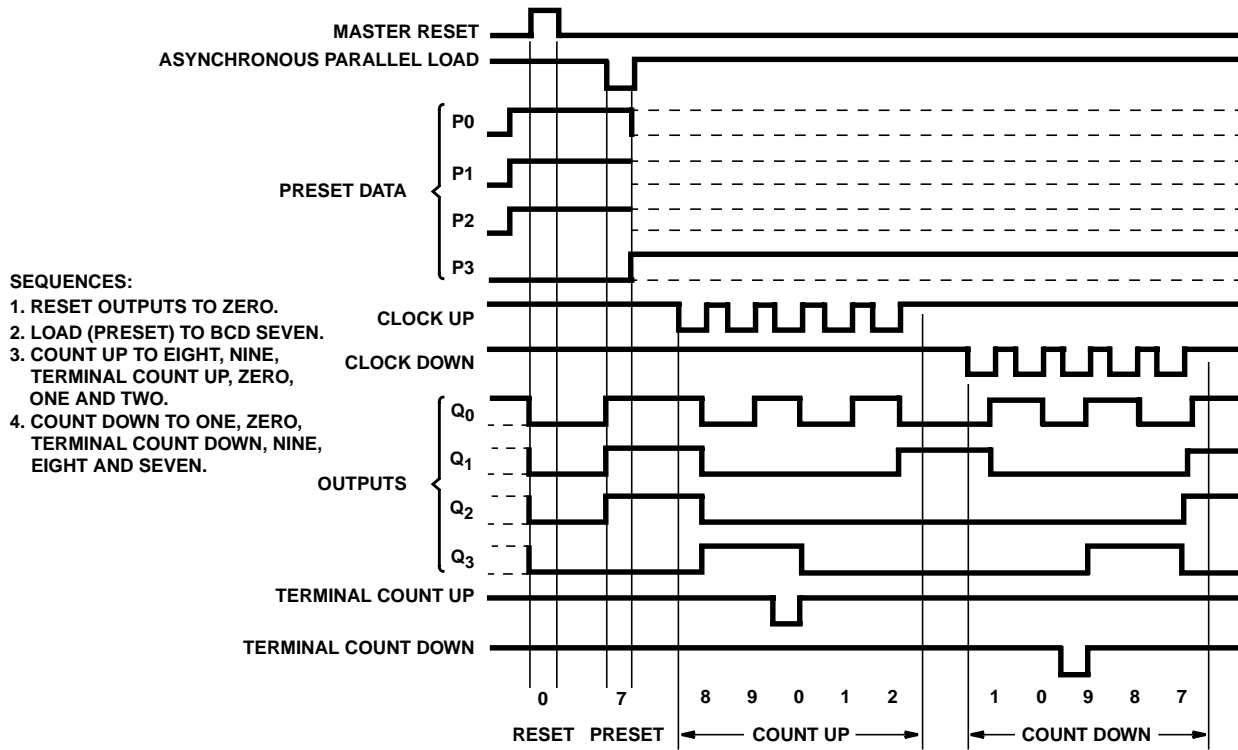

FIGURE 1. 'HC192 SYNCHRONOUS DECADE COUNTERS, TYPICAL RESET, PRESET AND COUNT SEQUENCES

Test Circuits and Waveforms (Continued)

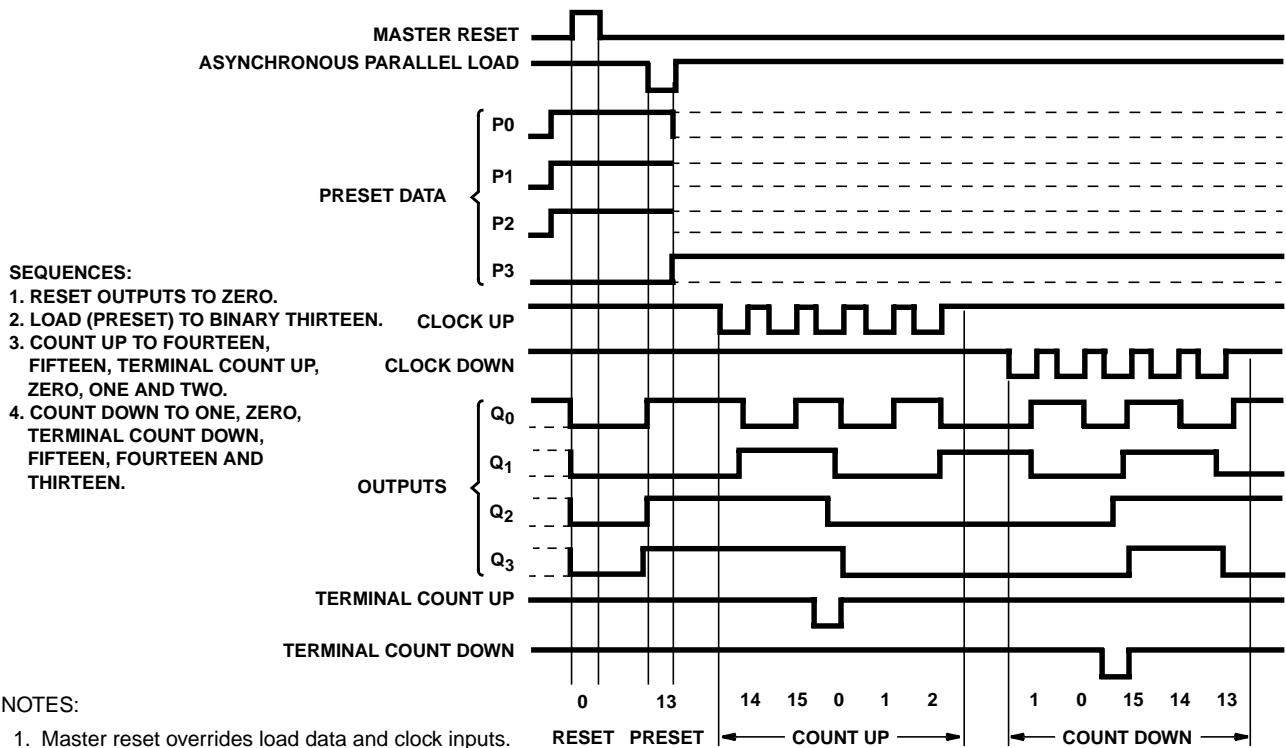

FIGURE 2. 'HC193 SYNCHRONOUS BINARY COUNTERS, TYPICAL RESET, PRESET AND COUNT SEQUENCES



FIGURE 3. CLOCK TO OUTPUT DELAYS AND CLOCK PULSE WIDTH



FIGURE 4. CLOCK TO TERMINAL COUNT DELAYS

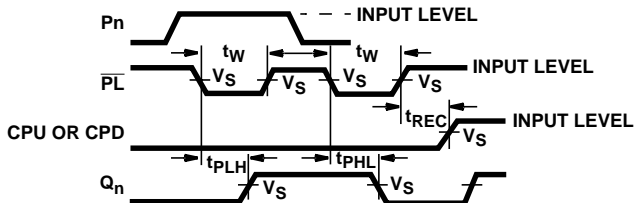

FIGURE 5. PARALLEL LOAD PULSE WIDTH, PARALLEL LOAD TO OUTPUT DELAYS, AND PARALLEL LOAD TO CLOCK RECOVERY TIME

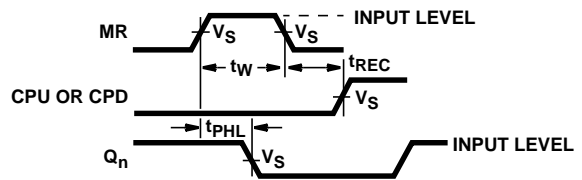

FIGURE 6. MASTER RESET PULSE WIDTH, MASTER RESET TO OUTPUT DELAY AND MASTER RESET TO CLOCK RECOVERY TIME

Test Circuits and Waveforms (Continued)

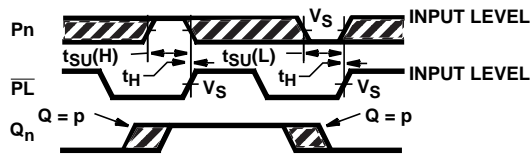

FIGURE 7. SET-UP AND HOLD TIMES DATA TO PARALLEL LOAD (PL)

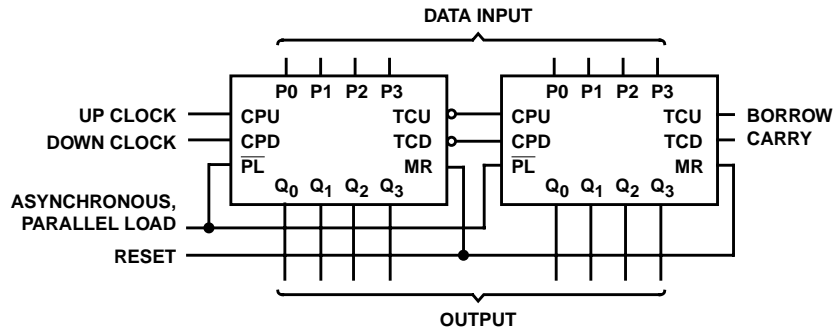

FIGURE 8. CASCADED UP/DOWN COUNTER WITH PARALLEL LOAD



NOTE: Illegal states in BCD counters corrected in one count.

NOTE: Illegal states in BCD counters corrected in one or two counts.

FIGURE 9. 'HC192, 'HCT193 STATE DIAGRAMS