

### Features

- Unlimited Input Rise and Fall Times
- Exceptionally High Noise Immunity
- Fanout (Over Temperature Range)
  - Standard Outputs . . . . . 10 LSTTL Loads
  - Bus Driver Outputs . . . . . 15 LSTTL Loads
- Wide Operating Temperature Range . . . -55°C to 125°C
- Balanced Propagation Delay and Transition Times
- Significant Power Reduction Compared to LSTTL Logic ICs
- HC Types
  - 2V to 6V Operation
  - High Noise Immunity:  $N_{IL} = 30\%$ ,  $N_{IH} = 30\%$  of  $V_{CC}$  at  $V_{CC} = 5V$
- HCT Types
  - 4.5V to 5.5V Operation
  - Direct LSTTL Input Logic Compatibility,  $V_{IL} = 0.8V$  (Max),  $V_{IH} = 2V$  (Min)
  - CMOS Input Compatibility,  $I_I \leq 1\mu A$  at  $V_{OL}$ ,  $V_{OH}$

### Description

The 'HC14 and 'HCT14 each contain six inverting Schmitt triggers in one package.

### Ordering Information

PART NUMBER	TEMP. RANGE (°C)	PACKAGE
CD54HC14F3A	-55 to 125	14 Ld CERDIP
CD54HCT14F3A	-55 to 125	14 Ld CERDIP
CD74HC14E	-55 to 125	14 Ld PDIP
CD74HC14M	-55 to 125	14 Ld SOIC
CD74HC14MT	-55 to 125	14 Ld SOIC
CD74HC14M96	-55 to 125	14 Ld SOIC
CD74HCT14E	-55 to 125	14 Ld PDIP
CD74HCT14M	-55 to 125	14 Ld SOIC
CD74HCT14MT	-55 to 125	14 Ld SOIC
CD74HCT14M96	-55 to 125	14 Ld SOIC

NOTE: When ordering, use the entire part number. The suffix 96 denotes tape and reel. The suffix T denotes a small-quantity reel of 250.

### Pinout

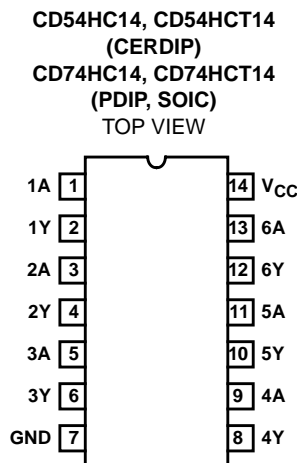

**Functional Diagram**

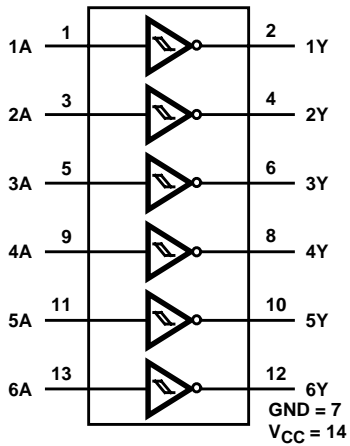

TRUTH TABLE

INPUT (A)	OUTPUT (Y)
L	H
H	L

H= High Level  
L= Low Level

**Logic Diagram**

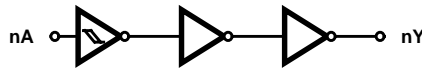

FIGURE 3. HYSTERESIS DEFINITION, CHARACTERISTIC, AND TEST SETUP

# CD54HC14, CD74HC14, CD54HCT, CD74HCT14

## Absolute Maximum Ratings

DC Supply Voltage, $V_{CC}$ .....	-0.5V to 7V
DC Input Diode Current, $I_{IK}$	
For $V_I < -0.5V$ or $V_I > V_{CC} + 0.5V$ .....	$\pm 20mA$
DC Output Diode Current, $I_{OK}$	
For $V_O < -0.5V$ or $V_O > V_{CC} + 0.5V$ .....	$\pm 20mA$
DC Drain Current, per Output, $I_O$	
For $-0.5V < V_O < V_{CC} + 0.5V$ .....	$\pm 25mA$
DC Output Source or Sink Current per Output Pin, $I_O$	
For $V_O > -0.5V$ or $V_O < V_{CC} + 0.5V$ .....	$\pm 25mA$
DC $V_{CC}$ or Ground Current, $I_{CC}$ .....	$\pm 50mA$

## Thermal Information

Thermal Resistance (Typical, Note 1)	$\theta_{JA}$ ( $^{\circ}C/W$ )
E (PDIP) Package .....	80
M (SOIC) Package .....	86
Maximum Junction Temperature (Hermetic Package or Die) . . .	175 $^{\circ}C$
Maximum Junction Temperature (Plastic Package) .....	150 $^{\circ}C$
Maximum Storage Temperature Range .....	-65 $^{\circ}C$ to 150 $^{\circ}C$
Maximum Lead Temperature (Soldering 10s) .....	300 $^{\circ}C$
(SOIC - Lead Tips Only)	

## Operating Conditions

Temperature Range, $T_A$ .....	-55 $^{\circ}C$ to 125 $^{\circ}C$
Supply Voltage Range, $V_{CC}$	
HC Types .....	.2V to 6V
HCT Types .....	4.5V to 5.5V
DC Input or Output Voltage, $V_I, V_O$ .....	0V to $V_{CC}$
Input Rise and Fall Time, $t_r, t_f$	
2V .....	100ms (Max)
4.5V .....	100ms (Max)
6V .....	100ms (Max)

*CAUTION: Stresses above those listed in "Absolute Maximum Ratings" may cause permanent damage to the device. This is a stress only rating and operation of the device at these or any other conditions above those indicated in the operational sections of this specification is not implied.*

### NOTE:

- The package thermal impedance is calculated in accordance with JESD 51-7.

## DC Electrical Specifications

PARAMETER	SYMBOL	TEST CONDITIONS		$V_{CC}$ (V)	25 $^{\circ}C$		-40 $^{\circ}C$ TO 85 $^{\circ}C$		-55 $^{\circ}C$ TO 125 $^{\circ}C$		UNITS	
		$V_I$ (V)	$I_O$ (mA)		MIN	MAX	MIN	MAX	MIN	MAX		
<b>HC TYPES</b>												
Input Switch Points	$V_{T+}$	-	-	2	0.7	1.5	0.7	1.5	0.7	1.5	V	
				4.5	1.7	3.15	1.7	3.15	1.7	3.15	V	
				6	2.1	4.2	2.1	4.2	2.1	4.2	V	
	$V_{T-}$	-	-	2	0.3	1.0	0.3	1.0	0.3	1.0	V	
				4.5	0.9	2.2	0.9	2.2	0.9	2.2	V	
				6	1.2	3.0	1.2	3.0	1.2	3.0	V	
	$V_H$	-	-	2	0.2	1.0	0.2	1.0	0.2	1.0	V	
				4.5	0.4	1.4	0.4	1.4	0.4	1.4	V	
				6	0.6	1.6	0.6	1.6	0.6	1.6	V	
High Level Output Voltage CMOS Loads	$V_{OH}$	$V_{T-}$ or $V_{T+}$	-0.02	-0.02	2	1.9	-	1.9	-	1.9	-	V
					4.5	4.4	-	4.4	-	4.4	-	V
					6	5.9	-	5.9	-	5.9	-	V
High Level Output Voltage TTL Loads		-	-	-	-	-	-	-	-	-	V	
		-4	-	4.5	3.98	-	3.84	-	3.7	-	V	
		-5.2	-	6	5.48	-	5.34	-	5.2	-	V	

**CD54HC14, CD74HC14, CD54HCT14, CD74HCT14**

**DC Electrical Specifications (Continued)**

PARAMETER	SYMBOL	TEST CONDITIONS		$V_{CC}$ (V)	25°C		-40°C TO 85°C		-55°C TO 125°C		UNITS
		$V_I$ (V)	$I_O$ (mA)		MIN	MAX	MIN	MAX	MIN	MAX	
Low Level Output Voltage CMOS Loads	$V_{OL}$	$V_{IH}$ or $V_{IL}$	0.02	2	-	0.1	-	0.1	-	0.1	V
			0.02	4.5	-	0.1	-	0.1	-	0.1	V
			0.02	6	-	0.1	-	0.1	-	0.1	V
Low Level Output Voltage TTL Loads	$V_{OL}$	$V_{IH}$ or $V_{IL}$	-	-	-	-	-	-	-	-	V
			4	4.5	-	0.26	-	0.33	-	0.4	V
			5.2	6	-	0.26	-	0.33	-	0.4	V
Input Leakage Current	$I_I$	$V_{CC}$ or GND	-	6	-	$\pm 0.1$	-	$\pm 1$	-	$\pm 1$	$\mu A$
Quiescent Device Current	$I_{CC}$	$V_{CC}$ or GND	0	6	-	2	-	20	-	40	$\mu A$

**HCT TYPES**

Input Switch Points	$V_{T+}$	-	-	4.5	1.2	1.9	1.2	1.9	1.2	1.9	V
				5.5	1.4	2.1	1.4	2.1	1.4	2.1	V
	$V_{T-}$			4.5	0.5	1.2	0.5	1.2	0.5	1.2	V
				5.5	0.6	1.4	0.6	1.4	0.6	1.4	V
	$V_H$			4.5	0.4	1.4	0.4	1.4	0.4	1.4	V
				5.5	0.4	1.5	0.4	1.5	0.4	1.5	V
High Level Output Voltage CMOS Loads	$V_{OH}$	$V_{IH}$ or $V_{IL}$	-0.02	4.5	4.4	-	4.4	-	4.4	-	V
High Level Output Voltage TTL Loads			-4	4.5	3.98	-	3.84	-	3.7	-	V
Low Level Output Voltage CMOS Loads	$V_{OL}$	$V_{IH}$ or $V_{IL}$	0.02	4.5	-	0.1	-	0.1	-	0.1	V
Low Level Output Voltage TTL Loads			4	4.5	-	0.26	-	0.33	-	0.4	V
Input Leakage Current	$I_I$	$V_{CC}$ and GND	-	5.5	-	$\pm 0.1$	-	$\pm 1$	-	$\pm 1$	$\mu A$
Quiescent Device Current	$I_{CC}$	$V_{CC}$ or GND	0	5.5	-	2	-	20	-	40	$\mu A$
Additional Quiescent Device Current Per Input Pin: 1 Unit Load	$\Delta I_{CC}$ (Note 2)	$V_{CC}$ - 2.1	-	4.5 to 5.5	-	360	-	450	-	490	$\mu A$

NOTE:

- For dual-supply systems theoretical worst case ( $V_I = 2.4V$ ,  $V_{CC} = 5.5V$ ) specification is 1.8mA.

**HCT Input Loading Table**

INPUT	UNIT LOADS
nA	0.6

NOTE: Unit Load is  $\Delta I_{CC}$  limit specified in DC Electrical Specifications table, e.g., 360 $\mu A$  max at 25°C.

### Switching Specifications Input $t_r, t_f = 6\text{ns}$

PARAMETER	SYMBOL	TEST CONDITIONS	$V_{CC}$ (V)	25°C			-40°C TO 85°C		-55°C TO 125°C		UNITS
				MIN	TYP	MAX	MIN	MAX	MIN	MAX	
<b>HC TYPES</b>											
Propagation Delay, A to Y	$t_{PLH}, t_{PHL}$	$C_L = 50\text{pF}$	2	-	-	135	-	170	-	205	ns
		$C_L = 50\text{pF}$	4.5	-	-	27	-	34	-	41	ns
		$C_L = 15\text{pF}$	5	-	11	-	-	-	-	-	ns
		$C_L = 50\text{pF}$	6	-	-	23	-	29	-	35	ns
Output Transition Times	$t_{TLH}, t_{THL}$	$C_L = 50\text{pF}$	2	-	-	75	-	95	18	110	ns
			4.5	-	-	15	-	19	-	22	ns
			6	-	-	13	-	16	-	19	ns
Input Capacitance	$C_I$	-	-	-	10	-	10	-	10	pF	
Power Dissipation Capacitance (Notes 3, 4)	$C_{PD}$	-	5	-	20	-	-	-	-	pF	
<b>HCT TYPES</b>											
Propagation Delay, A to Y	$t_{PLH}, t_{PHL}$	$C_L = 50\text{pF}$	4.5	-	-	38	-	48	-	57	ns
		$C_L = 15\text{pF}$	5	-	16	-	-	-	-	-	ns
Output Transition Times	$t_{TLH}, t_{THL}$	$C_L = 50\text{pF}$	4.5	-	-	15	-	19	-	22	ns
Input Capacitance	$C_I$	-	-	-	10	-	10	-	10	pF	
Power Dissipation Capacitance (Notes 3, 4)	$C_{PD}$	-	5	-	20	-	-	-	-	pF	

**NOTES:**

- $C_{PD}$  is used to determine the dynamic power consumption, per inverter.
- $P_D = V_{CC}^2 f_i (C_{PD} + C_L)$  where  $f_i$  = input frequency,  $C_L$  = output load capacitance,  $V_{CC}$  = supply voltage.

### Test Circuits and Waveforms

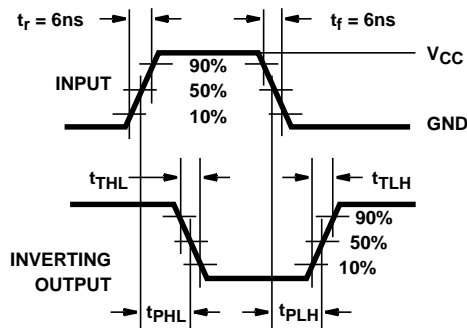

**FIGURE 4. HC TRANSITION TIMES AND PROPAGATION DELAY TIMES, COMBINATION LOGIC**

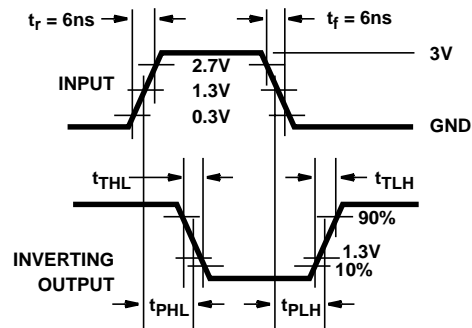

**FIGURE 5. HCT TRANSITION TIMES AND PROPAGATION DELAY TIMES, COMBINATION LOGIC**