

SN5430, SN54LS30, SN54S30
 SN7430, SN74LS30, SN74S30
8-INPUT POSITIVE-NAND GATES
 SDLS099 – DECEMBER 1983 – REVISED MARCH 1988

- Package Options Include Plastic "Small Outline" Packages, Ceramic Chip Carriers and Flat Packages, and Plastic and Ceramic DIPs
- Dependable Texas Instruments Quality and Reliability

description

These devices contain a single 8-input NAND gate.
 The SN5430, SN54LS30, and SN54S30 are characterized for operation over the full military range of -55°C to 125°C. The SN7430, SN74LS30, and SN74S30 are characterized for operation from 0°C to 70°C.

FUNCTION TABLE

| INPUTS A THRU H | OUTPUT Y |
|----------------------|----------|
| All inputs H | L |
| One or more inputs L | H |

logic diagram

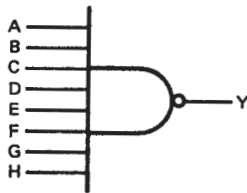

positive logic

$$Y = \overline{A \cdot B \cdot C \cdot D \cdot E \cdot F \cdot G \cdot H} \quad \text{or}$$

$$Y = \overline{A} + \overline{B} + \overline{C} + \overline{D} + \overline{E} + \overline{F} + \overline{G} + \overline{H}$$

logic symbol†

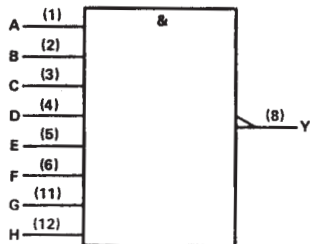

†This symbol is in accordance with ANSI/IEEE Std 91-1984 and IEC Publication 617-12.
 Pin numbers shown are for D, J, N, and W packages.

- SN5430 . . . J PACKAGE
- SN54LS30, SN54S30 . . . J OR W PACKAGE
- SN7430 . . . N PACKAGE
- SN74LS30, SN74S30 . . . D OR N PACKAGE

(TOP VIEW)

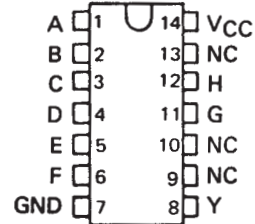

SN5430 . . . W PACKAGE

(TOP VIEW)

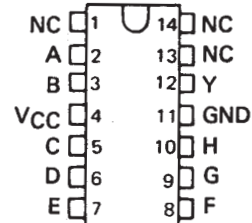

SN54LS30, SN54S30 . . . FK PACKAGE

(TOP VIEW)

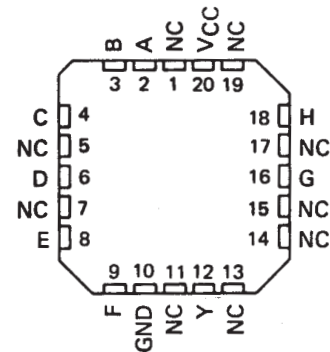

NC - No internal connection

SN5430, SN54LS30, SN54S30
 SN7430, SN74LS30, SN74S30
 8-INPUT POSITIVE-NAND GATES
 SDLS099 – DECEMBER 1983 – REVISED MARCH 1988

schematics (each gate)

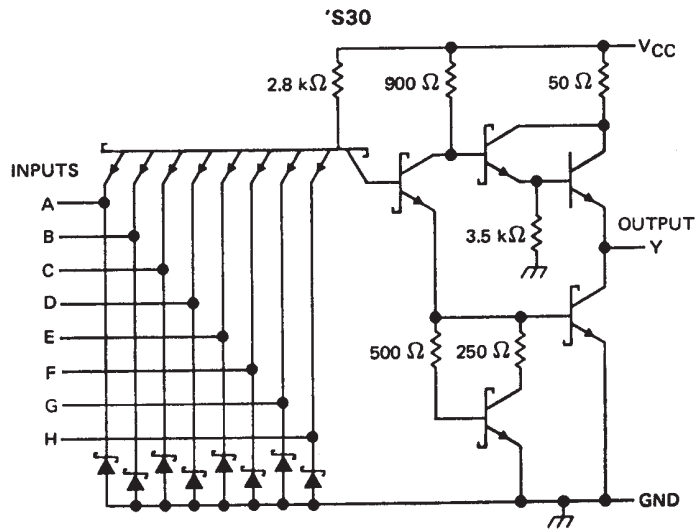
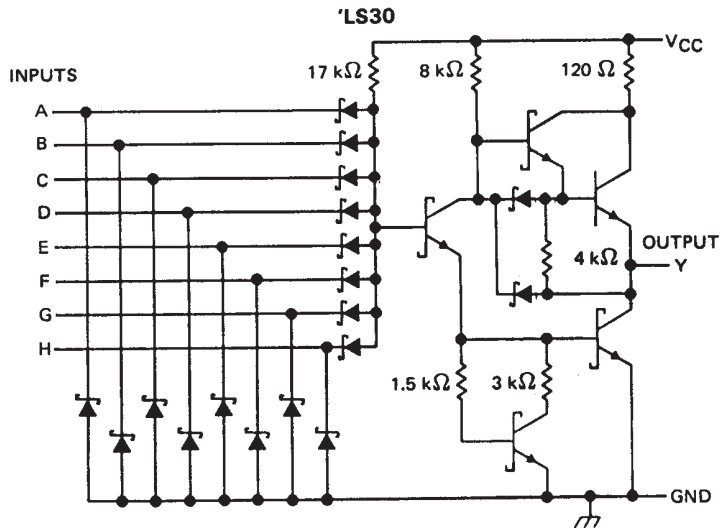
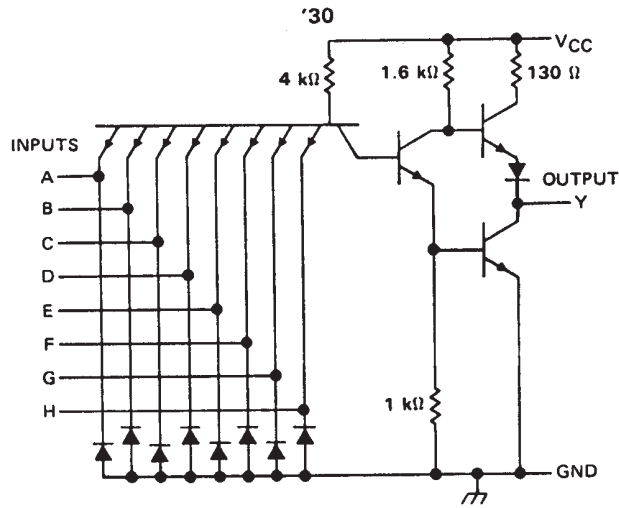

Resistor values shown are nominal.



absolute maximum ratings over operating free-air temperature range (unless otherwise noted)

| | |
|--|------------------|
| Supply voltage, V_{CC} (see Note 1) | 7 V |
| Input voltage | 5.5 V |
| Operating free-air temperature range: SN5430 | –55 °C to 125 °C |
| SN7430 | 0 °C to 70 °C |
| Storage temperature range | –65 °C to 150 °C |

NOTE 1: Voltage values are with respect to network ground terminal.

recommended operating conditions

| | SN5430 | | | SN7430 | | | UNIT |
|--------------------------------------|--------|-----|------|--------|-----|------|------|
| | MIN | NOM | MAX | MIN | NOM | MAX | |
| V_{CC} Supply voltage | 4.5 | 5 | 5.5 | 4.75 | 5 | 5.25 | V |
| V_{IH} High-level input voltage | 2 | | | 2 | | | V |
| V_{IL} Low-level input voltage | | | 0.8 | | | 0.8 | V |
| I_{OH} High-level output current | | | –0.4 | | | –0.4 | mA |
| I_{OL} Low-level output current | | | 16 | | | 16 | mA |
| T_A Operating free-air temperature | –55 | | 125 | 0 | | 70 | °C |

electrical characteristics over recommended operating free-air temperature range (unless otherwise noted)

| PARAMETER | TEST CONDITIONS † | SN5430 | | | SN7430 | | | UNIT |
|------------|---|--------|-------|------|--------|-------|------|------|
| | | MIN | TYP ‡ | MAX | MIN | TYP ‡ | MAX | |
| V_{IK} | $V_{CC} = \text{MIN}, I_I = -12 \text{ mA}$ | | | –1.5 | | | –1.5 | V |
| V_{OH} | $V_{CC} = \text{MIN}, V_{IL} = 0.8 \text{ V}, I_{OH} = -0.4 \text{ mA}$ | 2.4 | 3.4 | | 2.4 | 3.4 | | V |
| V_{OL} | $V_{CC} = \text{MIN}, V_{IH} = 2 \text{ V}, I_{OL} = 16 \text{ mA}$ | | 0.2 | 0.4 | | 0.2 | 0.4 | V |
| I_I | $V_{CC} = \text{MAX}, V_I = 5.5 \text{ V}$ | | | 1 | | | 1 | mA |
| I_{IH} | $V_{CC} = \text{MAX}, V_I = 2.4 \text{ V}$ | | | 40 | | | 40 | µA |
| I_{IL} | $V_{CC} = \text{MAX}, V_I = 0.4 \text{ V}$ | | | –1.6 | | | –1.6 | mA |
| $I_{OS} §$ | $V_{CC} = \text{MAX}$ | –20 | | –55 | –18 | | –55 | mA |
| I_{CCH} | $V_{CC} = \text{MAX}, V_I = 0$ | | 1 | 2 | | 1 | 2 | mA |
| I_{CCL} | $V_{CC} = \text{MAX}, V_I = 4.5 \text{ V}$ | | 3 | 6 | | 3 | 6 | mA |

† For conditions shown as MIN or MAX, use the appropriate value specified under recommended operating conditions.

‡ All typical values are at $V_{CC} = 5 \text{ V}, T_A = 25^\circ\text{C}$.

§ Not more than one output should be shorted at a time.

switching characteristics, $V_{CC} = 5 \text{ V}, T_A = 25^\circ\text{C}$ (see note 2)

| PARAMETER | FROM (INPUT) | TO (OUTPUT) | TEST CONDITIONS | MIN | TYP | MAX | UNIT |
|-----------|--------------|-------------|---|-----|-----|-----|------|
| t_{PLH} | Any | Y | $R_L = 400 \Omega, C_L = 15 \text{ pF}$ | | 13 | 22 | ns |
| t_{PHL} | | | | | 8 | 15 | ns |

NOTE 2: Load circuits and voltage waveforms are shown in Section 1.

**SN5430, SN54LS30, SN54S30
SN7430, SN74LS30, SN74S30
8-INPUT POSITIVE-NAND GATES**

SDLS099 – DECEMBER 1983 – REVISED MARCH 1988

absolute maximum ratings over operating free-air temperature range (unless otherwise noted)

| | |
|--|----------------|
| Supply voltage, V_{CC} (see Note 1) | 7 V |
| Input voltage | 7 V |
| Operating free-air temperature range: SN54LS30 | -55°C to 125°C |
| SN74LS30 | 0°C to 70°C |
| Storage temperature range | -65°C to 150°C |

NOTE 1: Voltage values are with respect to network ground terminal.

recommended operating conditions

| | SN54LS30 | | | SN74LS30 | | | UNIT |
|--------------------------------------|----------|-----|------|----------|-----|------|------|
| | MIN | NOM | MAX | MIN | NOM | MAX | |
| V_{CC} Supply voltage | 4.5 | 5 | 5.5 | 4.75 | 5 | 5.25 | V |
| V_{IH} High-level input voltage | 2 | | | 2 | | | V |
| V_{IL} Low-level input voltage | | | 0.7 | | | 0.8 | V |
| I_{OH} High-level output current | | | -0.4 | | | -0.4 | mA |
| I_{OL} Low-level output current | | | 4 | | | 8 | mA |
| T_A Operating free-air temperature | -55 | | 125 | 0 | | 70 | °C |

electrical characteristics over recommended operating free-air temperature range (unless otherwise noted)

| PARAMETER | TEST CONDITIONS † | SN54LS30 | | | SN74LS30 | | | UNIT |
|-----------|--|----------|------|------|----------|------|------|------|
| | | MIN | TYP‡ | MAX | MIN | TYP‡ | MAX | |
| V_{IK} | $V_{CC} = \text{MIN}, I_I = -18 \text{ mA}$ | | | -1.5 | | | -1.5 | V |
| V_{OH} | $V_{CC} = \text{MIN}, V_{IL} = \text{MAX}, I_{OH} = -0.4 \text{ mA}$ | 2.5 | 3.4 | | 2.7 | 3.4 | | V |
| V_{OL} | $V_{CC} = \text{MIN}, V_{IH} = 2 \text{ V}, I_{OL} = 4 \text{ mA}$ | 0.25 | 0.4 | | | | 0.4 | V |
| | $V_{CC} = \text{MIN}, V_{IH} = 2 \text{ V}, I_{OL} = 8 \text{ mA}$ | | | | 0.25 | 0.5 | | |
| I_I | $V_{CC} = \text{MAX}, V_I = 7 \text{ V}$ | | | 0.1 | | | 0.1 | mA |
| I_{IH} | $V_{CC} = \text{MAX}, V_I = 2.7 \text{ V}$ | | | 20 | | | 20 | µA |
| I_{IL} | $V_{CC} = \text{MAX}, V_I = 0.4 \text{ V}$ | | | -0.4 | | | -0.4 | mA |
| $I_{OS}§$ | $V_{CC} = \text{MAX}$ | -20 | | -100 | -20 | | -100 | mA |
| I_{CCH} | $V_{CC} = \text{MAX}, V_I = 0$ | 0.35 | 0.5 | | 0.35 | 0.5 | | mA |
| I_{CCL} | $V_{CC} = \text{MAX}, V_I = 4.5 \text{ V}$ | 0.6 | 1.1 | | 0.6 | 1.1 | | mA |

† For conditions shown as MIN or MAX, use the appropriate value specified under recommended operating conditions.
‡ All typical values are at $V_{CC} = 5 \text{ V}, T_A = 25^\circ\text{C}$
§ Not more than one output should be shorted at a time, and the duration of the short-circuit should not exceed one second.

switching characteristics, $V_{CC} = 5 \text{ V}, T_A = 25^\circ\text{C}$ (see note 2)

| PARAMETER | FROM (INPUT) | TO (OUTPUT) | TEST CONDITIONS | MIN | TYP | MAX | UNIT |
|-----------|--------------|-------------|--|-----|-----|-----|------|
| t_{PLH} | Any | Y | $R_L = 2 \text{ k}\Omega, C_L = 15 \text{ pF}$ | | 8 | 15 | ns |
| t_{PHL} | | | | | 13 | 20 | ns |

NOTE 2: Load circuits and voltage waveforms are shown in Section 1.



absolute maximum ratings over operating free-air temperature range (unless otherwise noted)

| | |
|---|------------------|
| Supply voltage, V_{CC} (see Note 1) | 7 V |
| Input voltage | 5.5 V |
| Operating free-air temperature range: SN54S30 | –55 °C to 125 °C |
| SN74S30 | 0 °C to 70 °C |
| Storage temperature range | –65 °C to 150 °C |

NOTE 1: Voltage values are with respect to network ground terminal.

recommended operating conditions

| | SN54S30 | | | SN74S30 | | | UNIT |
|--------------------------------------|---------|-----|-----|---------|-----|------|------|
| | MIN | NOM | MAX | MIN | NOM | MAX | |
| V_{CC} Supply voltage | 4.5 | 5 | 5.5 | 4.75 | 5 | 5.25 | V |
| V_{IH} High-level input voltage | 2 | | | 2 | | | V |
| V_{IL} Low-level input voltage | | | 0.8 | | | 0.8 | V |
| I_{OH} High-level output current | | | –1 | | | –1 | mA |
| I_{OL} Low-level output current | | | 20 | | | 20 | mA |
| T_A Operating free-air temperature | –55 | | 125 | 0 | | 70 | °C |

electrical characteristics over recommended operating free-air temperature range (unless otherwise noted)

| PARAMETER | TEST CONDITIONS † | SN54S30 | | | SN74S30 | | | UNIT |
|------------|---|---------|-------|------|---------|-------|------|------|
| | | MIN | TYP ‡ | MAX | MIN | TYP ‡ | MAX | |
| V_{IK} | $V_{CC} = \text{MIN}, I_I = -18 \text{ mA}$ | | | –1.2 | | | –1.2 | V |
| V_{OH} | $V_{CC} = \text{MIN}, V_{IL} = 0.8 \text{ V}, I_{OH} = -1 \text{ mA}$ | 2.5 | 3.4 | | 2.7 | 3.4 | | V |
| V_{OL} | $V_{CC} = \text{MIN}, V_{IH} = 2 \text{ V}, I_{OL} = 20 \text{ mA}$ | | | 0.5 | | | 0.5 | V |
| I_I | $V_{CC} = \text{MAX}, V_I = 5.5 \text{ V}$ | | | 1 | | | 1 | mA |
| I_{IH} | $V_{CC} = \text{MAX}, V_I = 2.7 \text{ V}$ | | | 50 | | | 50 | µA |
| I_{IL} | $V_{CC} = \text{MAX}, V_I = 0.5 \text{ V}$ | | | –2 | | | –2 | mA |
| $I_{OS} §$ | $V_{CC} = \text{MAX}$ | –40 | | –100 | –40 | | –100 | mA |
| I_{CCH} | $V_{CC} = \text{MAX}, V_I = 0$ | | 3 | 5 | | 3 | 5 | mA |
| I_{CCL} | $V_{CC} = \text{MAX}, V_I = 4.5 \text{ V}$ | | 5.5 | 10 | | 5.5 | 10 | mA |

† For conditions shown as MIN or MAX, use the appropriate value specified under recommended operating conditions.

‡ All typical values are at $V_{CC} = 5 \text{ V}, T_A = 25^\circ\text{C}$.

§ Not more than one output should be shorted at a time, and the duration of the short-circuit should not exceed one second.

switching characteristics, $V_{CC} = 5 \text{ V}, T_A = 25^\circ\text{C}$ (see note 2)

| PARAMETER | FROM (INPUT) | TO (OUTPUT) | TEST CONDITIONS | MIN | TYP | MAX | UNIT |
|-----------|--------------|-------------|---|-----|-----|-----|------|
| t_{PLH} | Any | Y | $R_L = 280 \Omega, C_L = 15 \text{ pF}$ | | 4 | 6 | ns |
| t_{PHL} | | | | | 4.5 | 7 | ns |
| t_{PLH} | | | $R_L = 280 \Omega, C_L = 50 \text{ pF}$ | | 5.5 | | ns |
| t_{PHL} | | | | | 6.5 | | ns |

NOTE 2: Load circuits and voltage waveforms are shown in Section 1.